

# CAN CHECKED

MFD28/32 Gen2 Manual



# Content

- 1 Description and scope of delivery ..... 6
- 2 Connection of the plugs ..... 7
- 3 Navigation on the display ..... 9
- 4 Logging ..... 11
- 5 Menu navigation on the display ..... 12
  - 5.1 Popup ..... 13
  - 5.2 Can Bus ..... 13
    - 5.2.1 TRI/TRX File ..... 14
    - 5.2.2 Can Speed ..... 14
    - 5.2.3 Can Term ..... 14
    - 5.2.4 Can Filter ..... 14
    - 5.2.5 Protocol ..... 14
    - 5.2.6 Can Switch ..... 14
    - 5.2.7 Timeout ..... 14
  - 5.3 Sensor Init ..... 15
  - 5.4 License ..... 16
  - 5.5 Gears ..... 16
  - 5.6 Splash Screen ..... 17
  - 5.7 Start Page ..... 17
  - 5.8 Shiftlight ..... 17
  - 5.9 Dim Sensivity ..... 17
  - 5.10 Pages ..... 17
  - 5.11 Custom Button ..... 19
  - 5.12 Demo Mode ..... 19
  - 5.13 Too Soon Junior ..... 19
  - 5.14 Night Mode ..... 20
  - 5.15 Units ..... 20
  - 5.16 AIN setup ..... 20
- 6 The TRI/TRX File ..... 21
  - 6.1 Name encoding of TRI/TRX files ..... 23
  - 6.2 Protocols ..... 23
  - 6.3 TRI/TRX file problem ..... 24
- 7 Adjust on the display ..... 26

8	Flashing the firmware.....	28
9	Customizing the display on the PC with the DSS.....	30
9.1	Connection .....	31
9.2	TRI Editor .....	33
9.2.1	Handling.....	33
9.2.2	Global enhanced mode .....	35
9.3	Pages.....	36
9.3.1	predefined pages.....	38
9.3.2	Widgets.....	39
9.3.2.1	General .....	40
9.3.2.2	Color selection.....	41
9.3.2.3	vertical bar .....	42
9.3.2.4	round meter .....	43
9.3.2.5	YT diagram .....	44
9.3.2.6	Enumeration .....	45
9.3.2.7	Icon .....	46
9.3.2.8	sensor value.....	47
9.3.2.9	Gear .....	50
9.3.2.10	Timer.....	51
9.3.2.11	Tire temp .....	52
9.3.2.12	G-meter .....	53
9.3.2.13	can switch .....	54
9.3.2.14	multi switch .....	55
9.3.2.15	horizontal bar .....	57
9.3.2.16	Needle .....	58
9.3.2.17	Overlay.....	60
9.3.2.18	Pixel .....	61
9.3.2.19	performance meter .....	62
9.3.2.20	status rectangle .....	63
9.3.2.21	rectangle.....	64
9.3.2.22	text field.....	65
9.3.2.23	picture.....	66
9.3.2.24	RPM bar .....	66
9.4	Log Viewer .....	69
9.5	Other settings.....	70
9.5.1	General settings.....	70

9.5.2	Can Bus .....	70
9.5.3	Shift light.....	70
9.5.4	Gears.....	70
9.5.5	Sensor init.....	71
9.5.6	IO pins.....	71
9.5.7	Can Transmit.....	72
9.5.8	User tables.....	73
9.5.9	Math Channels.....	74
9.5.10	Boost/PWM Control .....	75
9.6	Upload .....	76
9.7	Can Log .....	77
9.8	Work offline.....	77
10	AIN Setup (analog inputs).....	78
11	FAQ.....	80
11.1	TRI/TRX file problem .....	80
11.2	Display does not turn on .....	80
11.3	Display remains black or white.....	80
11.4	I don't get any data (no can) .....	80
11.5	Gear indicator does not work.....	81
11.6	Yellow bar at the bottom of the data display.....	81
11.7	My Performance Meter runs permanently .....	82
11.8	My shift flash doesn't work .....	82
11.9	How do I change my home logo? .....	82
11.10	How to get other logos on the pages .....	82
11.11	How do I rotate the UI of my display?.....	83
11.12	My DSS gets stuck on page X.....	83
11.13	How can I find the cached images of the DSS .....	83
11.14	How can I fine-tune a Can Bus sensor .....	83
11.15	I can no longer edit the sensors on the display.....	83
11.16	No connection with diagnostic tester possible .....	83
11.17	MicroSD card content and recovery.....	84
11.18	Resetting the display to factory settings.....	84
11.19	MaxxECU with PQ34/PQ35 drivetrain.....	84
11.20	MaxxECU Can Switching.....	85
11.21	How can I switch an output.....	87
11.21.1	Virtual button .....	87

11.21.2	Sensor threshold value .....	87
11.22	Can I dim my display.....	88
11.23	Can I change the page using an external button.....	89
11.24	I can't add, move or delete widgets.....	89

# 1 Description and scope of delivery

Thank you for purchasing your MFD28/32 Gen2. With the CANchecked data display, you can display live data from your vehicle while driving, *log sensors* and use many other functions that are presented to you in this manual.

This guide explains how to operate and handle your Gen2 data display. In addition to the connection, setup and navigation, this manual deals specifically with the individual setting and the connection and operation of our "Display Setup Software" (*DSS*).

You received your data display in a vehicle-specific mount or in one of our universal mounts. Depending on your order configuration, the contents of your original packaging may vary. Always included are:

- the quickstartguide
- 2 non reflective covers
- A SD card reader adapter
- CANchecked stickers
- One USB cable
- and **either** two Molex connectors (8 pin and 10 pin) and a choice of different pre-crimped leads **or** a pre-terminated OBD cable

Your display itself has a capacitive touch screen, two Molex connectors on the back, a MicroUSB port and a slot for a MicroSD card. The MicroSD card is always pre-assembled in your CANchecked data display and described by us with data for your vehicle.

The sensors and page configurations are stored on the microSD card. For faster charging and display, the display also has an internal flash memory. To remove the MicroSD card, after switching off the display, the SD card must be pressed in slightly with a suitable object or fingernail to loosen the latching nose. After pressing in, the MicroSD card springs out (**please proceed carefully so that it does not jump out uncontrollably**).

Terms associated with the data display are shown in italics in this guide for better understanding.

## 2 Connection of the plugs

To operate your MFD28/32 via the Can bus, only four wires are required:

- 12 volts on-board voltage, ideally ignition plus -> Pin A5
- Ground -> Pin A1
- Can High (*CanH*) -> Pin B2
- Can Low (*CanL*) -> Pin B3

Alternatively, you can replace 12 volts on-board voltage and ground with a USB power supply. For operation **in the vehicle, we expressly recommend a connection via 12-volt ignition plus and ground.** The wires of *CanH* and *CanL* are always designed as twisted pairs to minimize interference signals.

Important note: All pinout diagrams show the rear/cable side of the connector. Pin the wires exactly as shown in this view – do not mirror or rotate them.

Connector A has the Molex number 43025-0800, connector B 43025-1000 and crimps 43030-0001 must be used for both connectors.

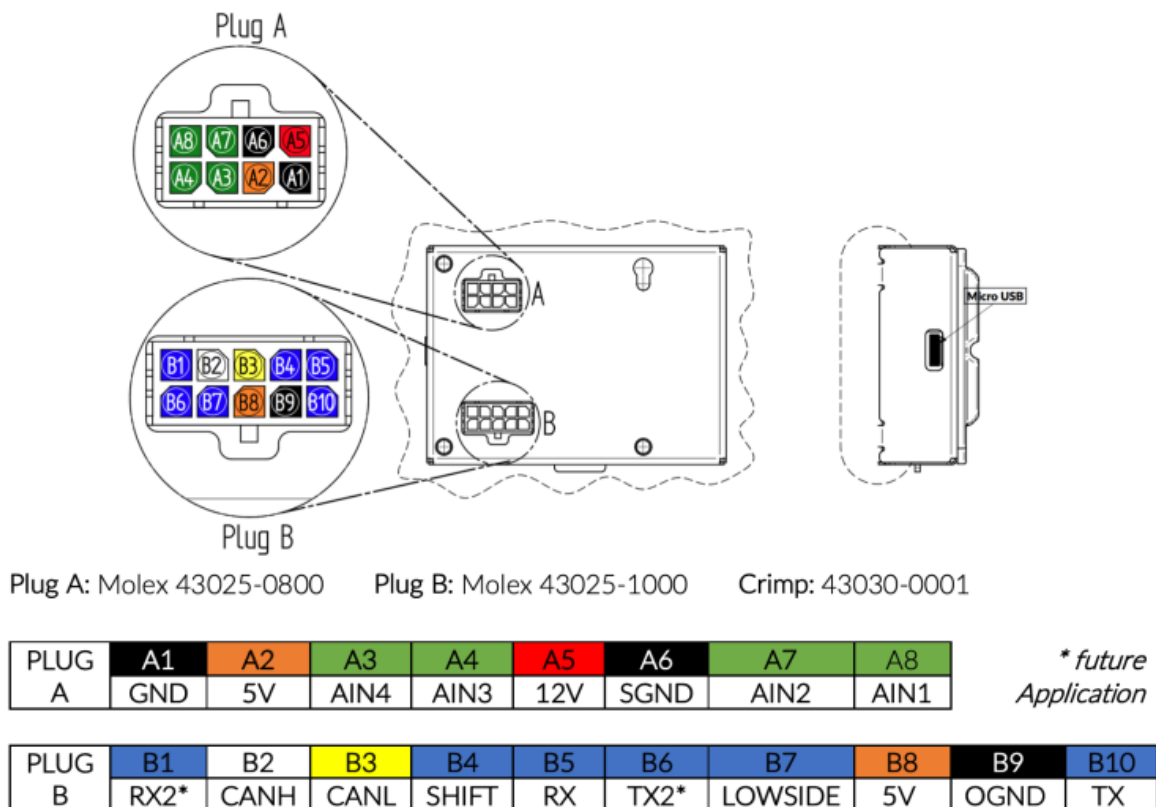

Figure 1: MFD28/32 Pinout

Of course, *CanH* and *CanL* are not necessarily necessary for operation. Via the four analog inputs (*AINs* – analog inputs) you can also feed the 0-5 volt voltages of analog sensors into the display and have them converted by the display and displayed on it.

By default, our *AINs* are preconfigured for different sensors:

- *AIN1*: Oil Temperature (*OilT*) -> Pin A8
- *AIN2*: Exhaust gas temperature (*EGT*) -> Pin A7
- *AIN3*: Oil pressure (*OilP*) -> Pin A4

- *AIN4*: Boost pressure (*MAP*)

-> Pin A3

The power supply for operating the analog sensors can also be realized directly via the display. Pin A2 and pin B8 are 5V during operation, and the sensor ground can be obtained from SensorGround A6. The maximum current of 0.5 amperes should not be exceeded.

Furthermore, the MFD28/32 Gen2 has a frequency input (max. 65kHz). With this you can separately feed wheel, engine or turbocharger speed (5V square wave signal) or the ethanol content of your fuel into the display. Pin B5 or B10 can be used for these applications. More information can be found [9.5.6](#).

Some settings can be implemented directly via the display. For detailed configuration or the creation of your own pages, the use of *DSS* (Display Setup Software) is necessary. The download is free of charge at <https://www.canchecked.de/downloads-category/dss-display-setup-software/>. The display is connected via the supplied USB cable. We recommend leaving it connected to the display and hiding the USB plug in an easily accessible place. In this way, easy access to your data display is possible at any time without disassembly. The glove compartment, the side covers of the dashboard, or the trim of the central consoles have established themselves here.

In the meantime, we have produced illustrated installation instructions for numerous vehicles. These can be found on our website under [www.canchecked.de/help/einbauanleitungen/](http://www.canchecked.de/help/einbauanleitungen/). If you have a CANchecked data display with a plug-and-play OBD data cable, it is recommended to connect it briefly with the data display to the OBD socket before final installation behind the fairing in order to check the correct connection and familiarize yourself with the user interface.

### 3 Navigation on the display

You can operate your display like any standard smartphone with touch and swipe gestures.

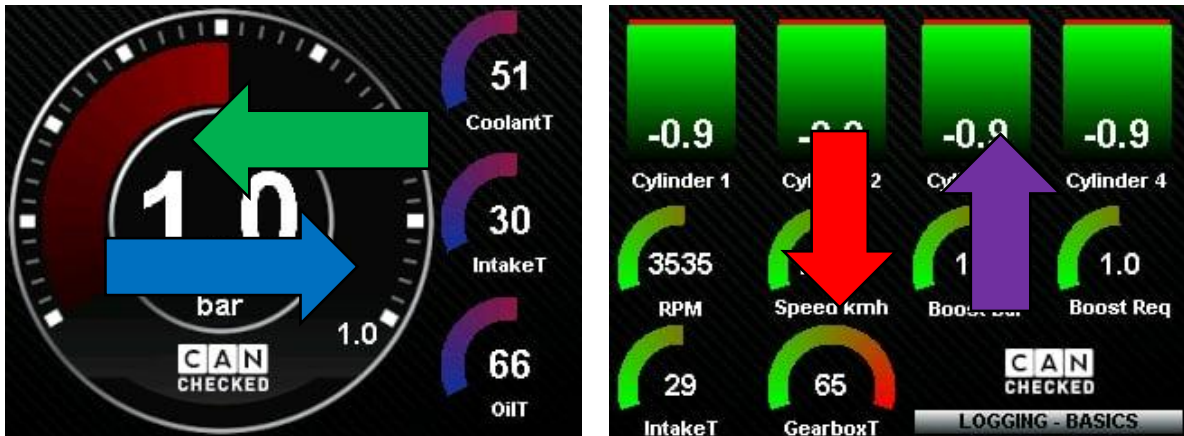

Figure 2: Gestures to operate the data display

To switch sides, simply swipe left (**one side forward**) or right (**one side back**) across the display.

During the page change, you will be shown in yellow in a cutscene which page you are on. If you switch to a blank page, the display in yellow font on a black background *Page is empty!* indicate.

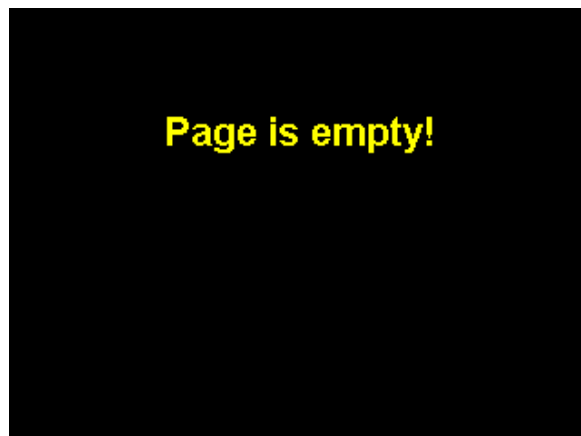

Figure 3: Appearance of a blank page

When delivered, most vehicles come with six pages pre-installed on your data display. In total, you can set up up to ten pages on your display as you like or use our *predefined pages* with the help of the *DSS* and get inspired, more about this in chapter 9.3.1

If you swipe down from top to bottom on your display (red arrow) you will be taken to the *setup* and *DTC* (not available on all vehicles and protocols, more on this in chapter 6.2).

In the setup you can make all settings relevant for the operation of the display. The menu navigation in *the setup* is described in chapter 5

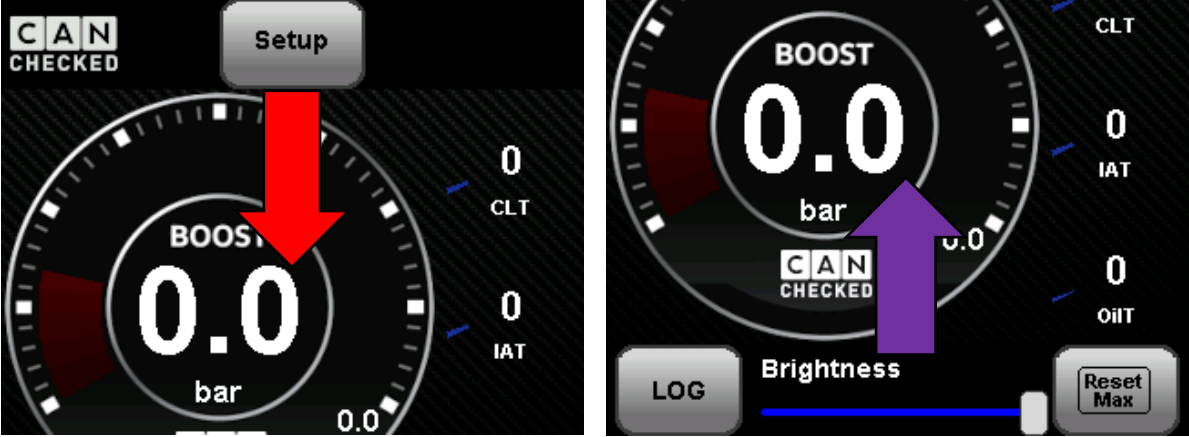

Figure 4: Setup and Quick Access Bar

If you swipe your finger from bottom to top (purple arrow) you open the *quick access bar*. These can be accessed from any of the ten pages. Here you will find the button for logging, the slider for the brightness of the display and a configurable *custom button*.

## 4 Logging

To start and stop the log, press the button in the bottom left-hand corner after swiping up. **Only the sensors visible on the page are logged.**

Vehicles that passively read the data from the drive scan (e.g. standalone ECU vehicles) are an exception to this. BMWs are a special case, as some of the sensors are read passively, but some also must be actively queried. To be on the safe side, you should therefore display every sensor requested in the log on your active page during logging. If you want to log a sensor but not display it on the page, you can use the pixel widget (section 9.3.2.18). You can find more information about the logs in chapter 6.2.

The *logs* are numerically incremented, and the button appears in green when the *log* is active. If you press the green button again, the *log* will end. The display counts the logs up to 255 and then starts again at 0. This number is not customizable. The number of the active *log* is displayed in the lower left corner, after three seconds the number turns into a small green status icon as long as the *log* is active. The **display only logs when the bar is pushed down**, if the bar is still pushed up the display does not log! Pushing the bar up interrupts the log.

On the SD card in the folder *logs* you will find the log files after successful logging. Alternatively, you can use the *Log Viewer* in the *DSS* to access your logs or delete them from the SD card. The logs are recorded every 62 ms (~16 Hz) and should not exceed one hour due to the overview. You can read more about this in chapter 9.4

The slider for activating and deactivating permanent logging can be found in the Sensor Init (compare chapter 5.3).

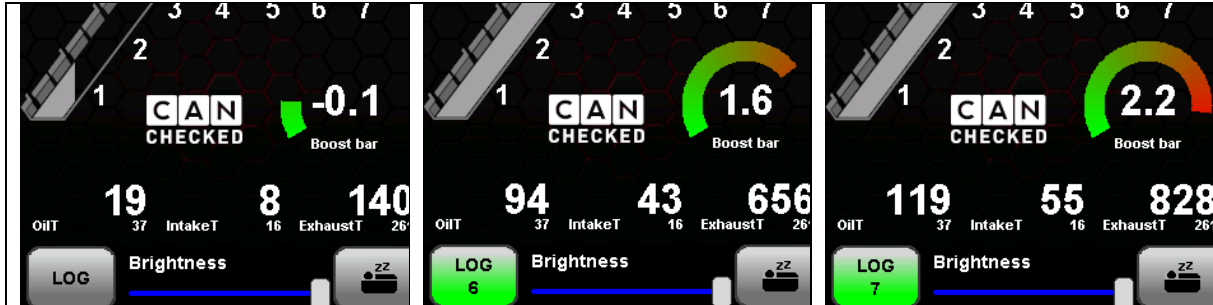

Figure 5: Button to start and stop the log

# 5 Menu navigation on the display

This chapter describes the menu navigation and the submenus of the *setup*. Each point of the *setup* is processed in a subchapter. The setup can always be terminated by clicking on the white **X** on a red background.



Figure 6: Setup

In the submenus you get back to the setup by pressing "<".

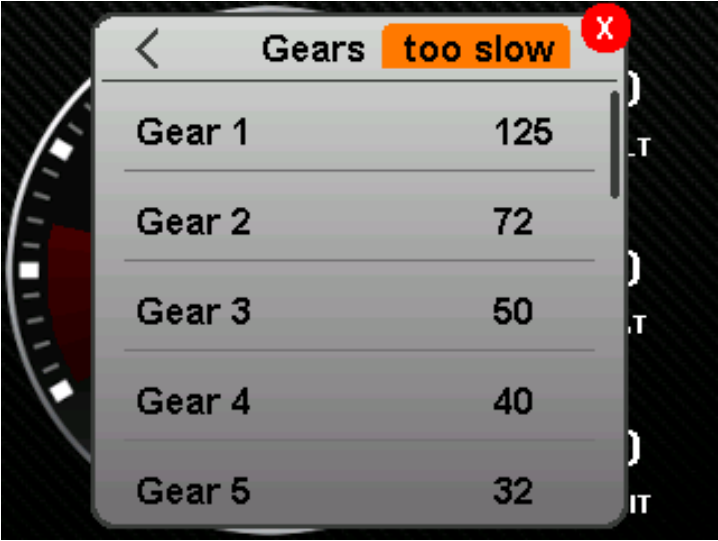

Figure 7: Screenshot from the menu

## 5.1 Popup

Your data display has the possibility to show you a blue or red *popup* when falling below or exceeding set *minimal* and maximal values.

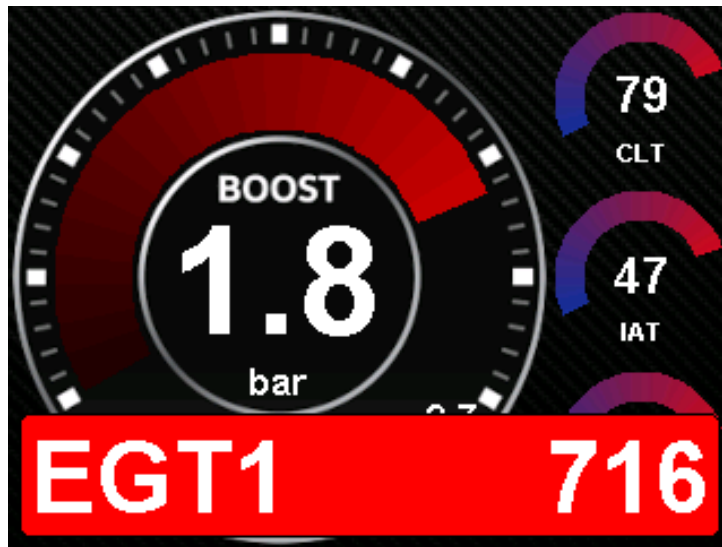

Figure 8: Red popup when exhaust gas temperature is too high

By default, the *pop-ups* are disabled both in the display and for each *sensor* individually. To activate the *popup*, it must be switched on globally in the setup under the menu item described here (see Figure 6) **and** the *minimal* or *maximal* values and the *popup* for the corresponding *sensor* must be activated in the *TRI file*9.2

In addition to switching the popup on and off, you can also set the length of time the *popup* remains on the screen by tapping the number of seconds. Dwell times of zero to five seconds are possible.

**ATTENTION:** Depending on the protocol used (OBD, TP2, UDS, BMW, BMWF), the display only queries the sensors queried on the current page. If, for example, a *popup* for the exhaust gas temperature is created, but this is not queried on the opened page you will get *no popup!*

Alternatively, you can use the *DSS* to create the *pixel widget*, which is invisible but adds a virtual sensor to the current view, allowing the popup and logging in. More about this in chapter 9.3.2.18.

## 5.2 Can Bus

In the Can Bus menu, you will see the status of your data connection at the top right. If the connection is successful there is **Can ok**, if the connection is not successful there is **no Can**.

In some protocols and firmwares, there is a lock in front of the submenus. Here, the settings are fixed in the firmware to exclude incorrect operation by the user. In this case, these settings can only be adjusted via the *DSS*.

### 5.2.1 TRI/TRX File

Under the submenu item TRI/TRX File you can select the *TRI/TRX* File you need from a list or scan your engine data (UDS only) if your engine code letter (MKB) is not yet in the list to start a service request under [info@canchecked.de](mailto:info@canchecked.de). Depending on which firmware is installed on your display, you may only find *TRI/TRX* files that start with S-XXX, T-XXX, U-XXX or O-XXX. If you want to see other TRI/TRX files you have to flash the appropriate firmware. More information can be found in chapter 6.2

### 5.2.2 Can Speed

In this sub-item you can set the speed of your Can bus by clicking on the number. Our data display currently supports the following speeds of 125, 250, 500 and 1000 kbit/s.

### 5.2.3 Can Term

This slider can be used to activate or deactivate a 120 Ohm Can Bus terminator.

### 5.2.4 Can Filter

By clicking on this submenu, various can *filters* (OBD or vehicle-specific) can be activated or deactivated.

### 5.2.5 Protocol

With active *protocols*, there is a slider in the menu here to switch the *protocol* on or off, thus locking or unlocking the OBD socket. Deactivating the protocol may be necessary, for example, to access the ECUs via a diagnostic tool. For later operation of the data display, however, the protocol must then be reactivated thus the OBD socket must be blocked again.

### 5.2.6 Can Switch

Your Gen2 data display can not only receive Can Bus data, but also send it. These can be:

- Touch Button Status (on/off, e.g., to activate Launch Control, ALS or a fan)
- Forwarding of the 4 analog inputs or the digital inputs to the control unit
- Converting Can Bus messages to other addresses

In the Can *Switch* submenu, a selection of Can Switches can be made by clicking on the setting. The following settings are currently offered:

- Off (no Can Switches activated)
- Custom (Can switches can be configured via *DSS* 9.5.7)
- EMU v3
- LinkECU
- MaxxECU => see also 11.20
- Motec
- Haltech

With the preconfigured Can *Switches*, the data display emulates the manufacturer specific Can Switch boards (Ecumaster) or ready-made messages, which can be found in our specific instructions for the ECUs or in the FAQ chapter 11.20 at the end of this manual.

### 5.2.7 Timeout

In the *Timeout* submenu, the length of the *timeout* until the next data query for logs can be set by tapping on the number. By default, this is two milliseconds. The time can be set in increments from two to 20.

### 5.3 Sensor Init

In the *Sensor Init* submenu, individual sensors are assigned to essential functions of the data display .

For assignment, the corresponding *sensor* must be clicked on and can then be selected from the list of available *sensors* by clicking on it. The successful dialing is indicated by a **green** box. The *sensor init* can always be terminated by clicking on the white **X** on a red background (changes are saved automatically). By pressing < you get from the submenu back to the *sensor init*.

The essential functions and their default values in the *sensor init* are shown in Table1.

Table1: Essential functions in the *Sensor Init*

Essential function	Needed for	Default value
RPM	Gear calculation und <i>Shiftlight</i>	RPM
Speed	Gear calculation	Speed
Page Switch	Changing the settings by a Can message with a status of 1-10	N/A
Dim Display	Dimming of the Display by a Can message	N/A
Haldex Ext	Setting the Haldex <i>widjet</i>	N/A
Gear	<i>Sensor</i> in TRI/TRX File for <i>Gearwidjet</i>	Gear
Gear Mode	<i>Sensor</i> in TRI/TRX File for <i>Gearwidjet</i>	Automatic: Gear Mode
		Manual: N/A

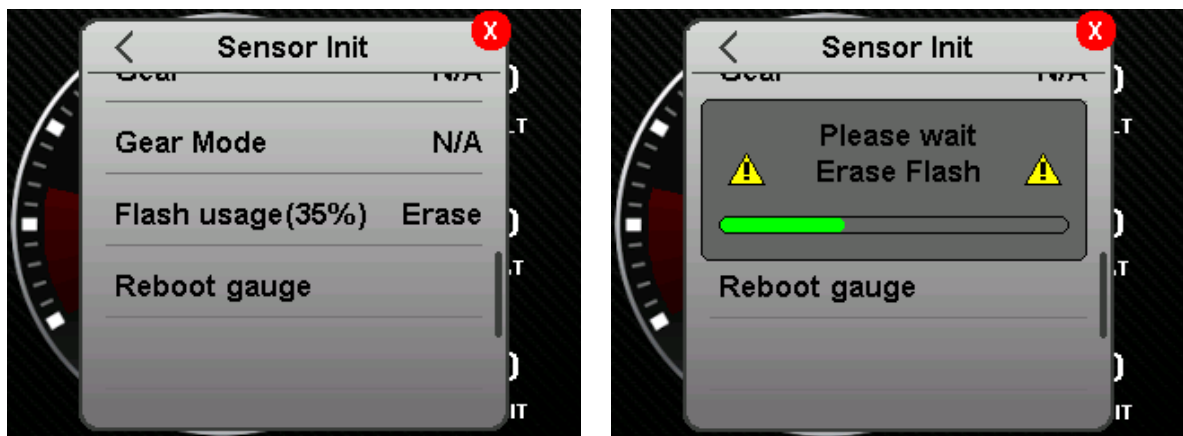

Figure 9: *Sensor Init*

In addition to the settings of the essential *sensors* , the *Sensor Init* also contains *Flash usage* and *Reboot gauge*. Behind the words *Flash usage* is the current percentage utilization of the flash memory in parentheses. As well as behind it the button to erase the flash memory.

**Attention:** if you delete the flash memory, all images from the SD card are initially loaded into the flash memory the next time the data display is restarted. The start animation of the display **jerks** and the **first loading** of the pages can be a bit slower.

By clicking on the *lettering Reboot gauge* , a restart of the data display is forced without disconnecting the power supply.

In the last item of the sensor init you will find the slider for permanent logging. This can be used to activate/deactivate permanent logging with each ignition change.

#### 5.4 License

Under the *License* submenu, information about your data display can be found. Here you will find the serial number of your device and the currently installed software version.

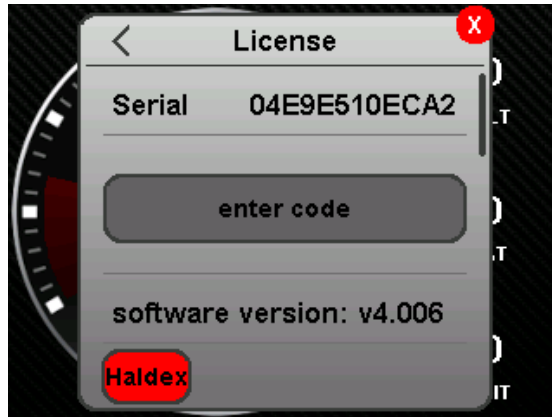

Figure 10: License

Furthermore, you can enter the license codes to activate paid additional functions here. At the bottom of the screen, you will find feedback on the activated additional functions such as the Haldex license. If this is **red** no license is active, if this **green** is the corresponding function is active.

#### 5.5 Gears

In the Gears submenu, the gear ratios can be entered for gears one to eight. Based on the ratios stored here, the display shows you the gears in the internal *sensor Gearcalc*.

The gear ratio is defined as follows:

$$gear\ ratio = \frac{RPM \left[ \frac{1}{min} \right]}{speed \left[ \frac{km}{h} \right]}$$

To enter the gear ratios, simply click on the corresponding gear and then enter your gear ratio there via the opening keyboard.

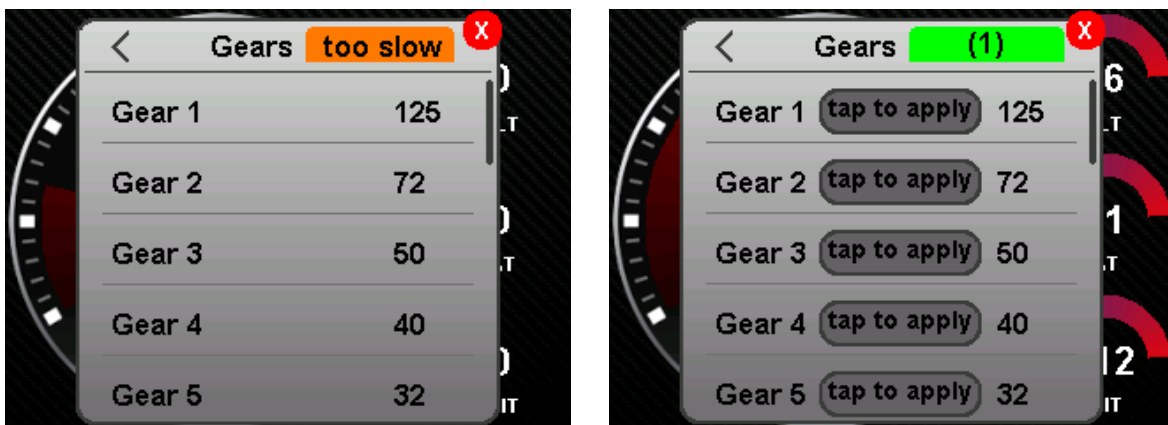

Figure 11: Gear device

To save you time, nerves and a calculator when setting up your gear indicator, we have created a setup gadget in the *Gears* submenu. When the vehicle is stationary, you will see too slow in the

submenu at the top right. If your vehicle starts moving, the display changes and you get your current gear ratio displayed at the top right of the screen (X). Now you can drive in any gear and then press on your data display on the corresponding gear to take over the ratio for this, turning off the engine is not necessary. Unused gears must be manually set to 0 when stationary.

## 5.6 Splash Screen

The *splash screen* is the start image/animation of your data display. In this menu you can set whether and for how long the *splash screen* should be displayed when your data display is switched on. By tapping the number, you can switch between off and a time of zero to ten seconds.

## 5.7 Start Page

Under Start *Page* you can set on which page your display should be after starting. Here you have the choice between sides one to ten or *last used*. With this option, your display starts on the side that was active when the data display was switched off. Switching between the different options is analogous to switching the *splash screen* by clicking on it.

## 5.8 Shiftlight

In the *submenu Shiftlight* you can configure the behavior of your **external** shift flash. Here you can set the color and the activation speed threshold for each of the eight switching flash LEDs by tapping them.

Furthermore, you can set the speed threshold (*RPM flash*), at which all eight LEDs start flashing. Other menu items are the global brightness of the LEDs (*brightness*) and the direction of the gradient (*left2right* or *right2left*).

## 5.9 Dim Sensivity

Under this submenu you can adjust the amount of dimming of your display via the essential function *Dim Display*5.3

**ATTENTION:** At 100%, the display is almost unreadable.

## 5.10 Pages

In the submenu *Pages* you will find a tab for predefined *widgets packs*. If you have stored them on your SD card, you can select and activate them here. **FEATURE REMOVED and replaced by CHANGE PAGE STYLE!**

For each *page* on your data display, you'll also find two sliders here. If you only have one slider to enable or disable, you will find a global slider switch for all pages at the bottom of this submenu.

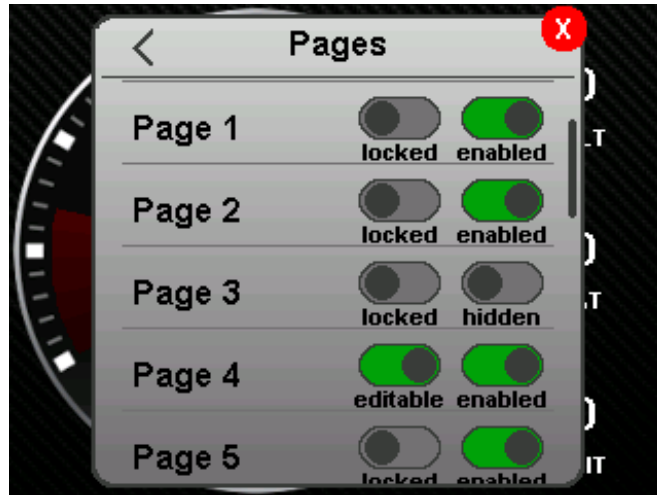

Figure 12: Pages

The left slider locks or unlocks ("editable") the *pages* for editing. By default, editing is locked.

The right slider enables ("enabled") or hidden *pages*. With this function, for example, your display can only have three *pages* (page 4-10 hidden) and jumps back to the first page after the third *page*.

The last item of this submenu is the *orientation* of your data display. The user interface can be aligned in all four spatial directions. Horizontal, *vertical*, *horizontal2* and *vertical2* are available as options. After a change, a restart of the display is necessary. This can be done by disconnecting the power supply or by rebooting (described in Chapter 5.3).

### 5.11 Custom Button

The *custom button*, if activated, can be found at the bottom right of the *quick access bar*. By clicking next to the *Custom Button* lettering in the *setup* you can switch through the possible options.

As of software version 4.008, the following options are available:

Table 2: Custom Button

Option	Description
OFF	The <i>custom button</i> is not active and is not displayed
Sleep	Display turns black and only lights up again with the next touch
Reset Max	Resets the operating maximum values of the <i>sensors</i>
Can Switch	Quick access to one of the 8 can switches
Panic	Fixed display of 3 bar charts, touch is deactivated
Can Switch	Can Switch 1, 2 or 3 for fast access

The pin for the panic button can be set via the Set Pin button. By default, the pin is set to 0000. If you have forgotten the pin, you must flash your display via CANcheckedUpdater with the reset-to-default\_GEN2.hex from the Gen2 download area of our website to regain access.

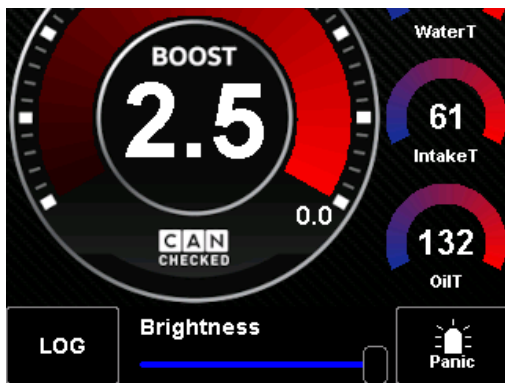

Figure 13: Position of the Panic Button

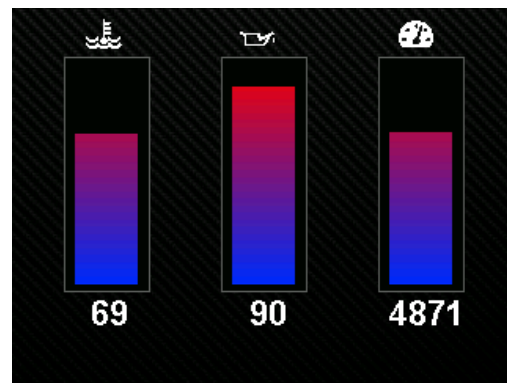

Figure 14: View during active Panic Button

If you have activated the panic button and are on the view with the three fixed bar graphs, you have to hold the touch screen down in one place for at least three seconds to access the keypad to enter the pin.

### 5.12 Demo Mode

The slide switch for the *demo* mode activates the demonstration mode of your data display. In this mode, all *sensors* created in the *TRI/TRX* file will oscillate between their *minimum* and *maximum* value. For example, you can use this feature to show your friends how cool your new data display is.

However, this function is particularly interesting when setting up new *pages* to simulate later operation and to get an idea of how your freshly created page will look in later use. The demo mode can also be started directly from the program during setup with the 9.3(chapter 9.3).

### 5.13 Too Soon Junior

You've worked your way through the *setup* and come across *Too Soon Junior* ? Does the sentence sound familiar to you somewhere? Congratulations, you've found the first Easter Egg. Activate the slider, close the setup and push your accelerator to the ground.

(The *sensor* TPS or throttle must be in position number 26 in the *TRI/TRX* file for this easter egg to work)

### 5.14 Night Mode

You can use this slider to change the entire menu navigation of your MFD28/32 Gen2 from the bright daytime version to the darkened nighttime version. This setting is not reset with the next display restart but remains active until you change it again.

### 5.15 Units

Depending on the TRI/TRX file, you can set the units to be used here. To do this, please **ensure that a metric TRI/TRX file (X-XXX-M / X-XXX) is loaded**, and the sensor type is assigned for each sensor. **If an imperial or mixed file is already being used as the basis, the display will not calculate plausible values** when changes are made in this menu! Please compare chapter 6 column position 26. If you have a TRI/TRX file with only 25 column positions, you can add the sensor type manually in the DSS. Please refer to chapter 9.2.

### 5.16 AIN setup

Under AIN Setup, you can select the characteristic curves for your analogue sensors from our preconfigured sensors without having to connect the display to the DSS.

Once you have selected the relevant AIN, you can use the arrow buttons to select the connected sensor and activate it by clicking 'use calibration'.



Figure 15: AIN setup

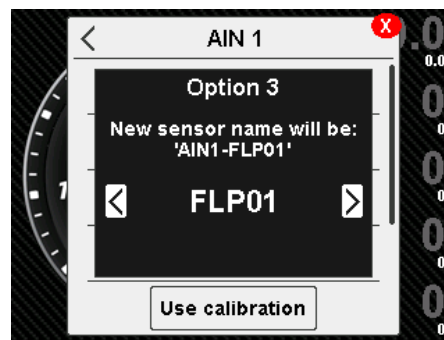

Figure 16: AIN Calibration

You can choose from the following sensors:

- |          |  |         |
|----------|--|---------|
| • Custom | Mapping takes place via the DSS                |         |
| • NTC01  | Our in-house temperature sensor for liquids    | CC22915 |
| • FLP01  | Our in-house pressure sensor for liquids/EMAP  | CC22901 |
| • BST01  | Our in-house boost sensor                      | CC22900 |
| • TCC01  | Our in-house Typ-K converter (1000/1250)       | CC22903 |
| • BoschT | Bosch combi sensor temperature with 1k pull-up |         |
| • BoschP | Bosch combi sensor pressure                    |         |

## 6 The TRI/TRX File

The TRI or *TRI*. *TRX File* is the heart of your data display. All *sensors* and the associated information are stored in the *TRI file*. In principle, every *TRX* file is a *TRI file*, but some information is encrypted in it. Data displays for freely programmable engine ECUs are always delivered with *TRI File* and data displays for vehicle-specific protocols are usually delivered with *TRX File*.

In the following, the structure of a *TRI/TRX file* is explained. If you open the file with a text editor, you will find the following structure:

Each line represents a sensor and all metadata associated with the sensor. These 26 metadata are in columns, separated by semicolons. The decimal separator is a period, not a comma. The figure below shows a *TRI file* with two sensors (RPM and CLT) and the metadata associated with the *sensors*.

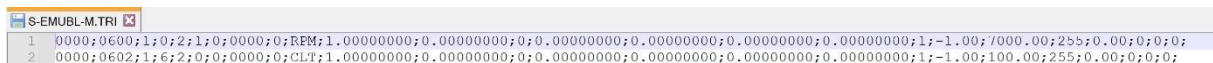

```
S-EMUBL-M.TRI
1 0000;0600;1;0;2;1;0;0000;0;REM;1.00000000;0.00000000;0;0.00000000;0.00000000;0.00000000;0.00000000;1;-1.00;7000.00;255;0.00;0;0;0;
2 0000;0602;1;6;2;0;0000;0;CLT;1.00000000;0.00000000;0;0.00000000;0.00000000;0.00000000;0.00000000;1;-1.00;100.00;255;0.00;0;0;0;
```

Figure 17: *TRI File* in the text editor

The column position of the 26 metadata is fixed in each row. For example, the *Can ID* of the respective *sensor* is always in the second column.

Table 3 shows the column positions, the designation, the purpose and peculiarities of the metadata. The values marked in blue are only visible in *enhanced mode in DSS* (more on this in chapter 9.2.2).

Table 3: TRI/TRX data

column position	Designation	Purpose and particularities
1	<i>Header</i>	bus header for OBD/UDS (hexadecimal) 0 = no protocol or specific Can Bus Identifier for protocol
2	<i>Can ID</i>	Can Bus Identifier (hexadecimal) when using OBD/UDS/TP2.0: Address for querying the device
3	<i>Format</i>	0 -> Big endian; 1-> little endian; 2 -> VEMS (serial); 4 -> IEEE-754 float (Lenght=4)
4	<i>Start byte</i>	First byte in Can Bus packet (0-7)
5	<i>Length</i>	Length in bytes - 1, 2 or 4 for AINs: Attenuation strength 0-249 (0 = no attenuation)
6	<i>unsigned</i>	if the value is negative, please do not tick the box
7	<i>shift Bit</i>	moves the bit within the value to the right by position X
8	<i>CAN Mask</i>	Masks the value before shift (0 -> no mask applied)
9	<i>Decimal places</i>	Number of decimal places
10	<i>Sensor Name</i>	Sensor name (maximum 15 characters, no special characters)
11	<i>initCalc</i>	Can Bus value gets multiplied by this number Result= ((Can Bus value & MASK)>>SHIFT) *INITCALC+INITOFFSET
12	<i>initOffset</i>	after multiplication this value is added
13	<i>Multiplex / MapperType</i>	OFF, MAP (linear analog sensors); NTC (3 constants and pull-up resistor (Steinhart-Hart))
14	<i>start bit / MapperInfo1</i>	Multiplex start bit / Varies by mapper type
15	<i>bit length / MapperInfo2</i>	Multiplex bit length / Varies by mapper type
16	<i>Multiplexer / MapperInfo3</i>	Multiplexer / Varies by mapper type
17	<i>Multiplier / MapperInfo4</i>	Global multiplication factor for the sensor (default value 1) / Varies depending on mapper type
18	<i>AIN active</i>	Internal analog sensor only; enables input pin polling
19	<i>Min</i>	Lower warning value
20	<i>Max</i>	Upper warning value
21	<i>RefSensor</i>	reference sensor: only if the RefValue for this sensor is exceeded, warning is active
22	<i>RefValue</i>	Reference value for enabling the alert
23	-	Not in use
24	<i>Pop</i>	Popup active when exceeding or falling below the warning value
25	-	Not in use
26*	<i>Sensor type*</i>	Used for units calculation: 0=none; 1=pressure; 2=temperature; 3=speed; 4=combustion ratio

\*not included in all files - add via DSS if required or request by e-mail

## 6.1 Name encoding of TRI/TRX files

Our *TRI/TRX files* always have the following name:

OLD:

$X - ABC - X.TRI$  or  $X - ABC - X.TRX$

NEW:

$X - ABC.TRI$  or  $X - ABC.TRX$

The **first** letter identifies the *protocol* used. More information on the *protocols* can be found in Chapter 6.2

The letters **two to four** identify the engine code letter or ECU. The engine code DAZA becomes X-DAZ-X or a Syvecs ECU becomes X-SYV-X here. For freely programmable ECUs, however, the names can also be longer than three digits (e.g. MaxxECU -> X-MAXX-X). The maximum number of digits including ending is 8 characters.

The **fifth or fifth** last letter in the name of the *TRI/TRX file* indicates the units or languages used to name the *sensors*:

- **-G** stands for the language German and units metric
- **-M** stands for the English language and the units metric
- **-I** stands for the language English and the units imperial
- **-H** stands for hybrid here is the language English and the units partly imperial, partly metric, more detailed information can be found in the enclosed Quickstartguide
- **-U** stands for UK, here is also a mix of imperial and metric data

Meanwhile all TRI-/TRX-Files are in english and metric, the desired units get set on the display itself.

## 6.2 Protocols

CANchecked data displays support a variety of CAN protocols. For the different protocols, there are different firmware for your data display:

- standalone engine control units (ECUs) use the **standard/OBD2 firmware** (S-ABC. TRI)
- Direct access to the vehicle Can Bus (S-ABC. TRX)
- Data retrieval with OBD2 protocol uses **the standard/OBD2 firmware** (O-ABC.TRX)
- the TP2 protocol is used with the **TP2 firmware** (T-ABC.TRX)
- Vehicles that allow UDS protocol use **the UDS firmware** (U-ABC. TRX)
- BMW E/F series for vehicles of the E and F series (B-ABC. TRX)

Depending on the installed firmware, you will only see TRI/TRX files for the corresponding firmware in the *TRI/TRX* selection list of the display. All files for other firmware will be hidden. For example, if UDS firmware is installed, you will not see TRI/TRX files for standalone ECUs, but only files with "U-". More information on changing and updating the firmware can be found in Chapter 8.

### 6.3 TRI/TRX file problem

If your data display starts and no *TRI/TRX file* is selected or present on the display, you will receive an error message in a large yellow box.

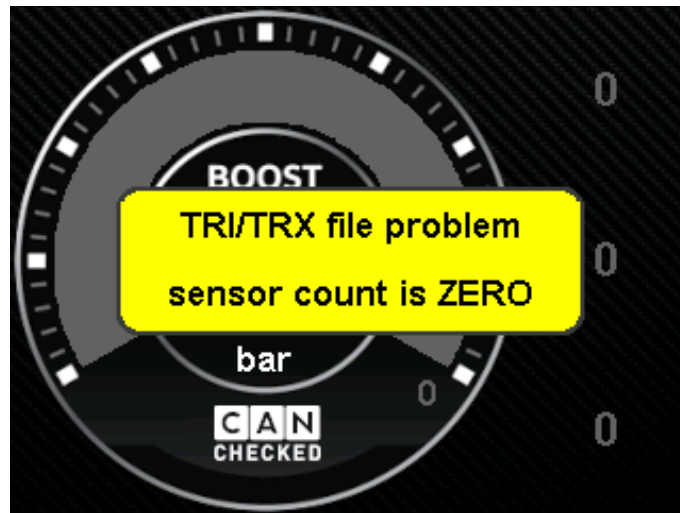

Figure 18: TRI/TRX error message

To select a TRI/TRX file, navigate to the list of files available on the SD card via *Setup -> Can Bus -> TRI/TRX File*.

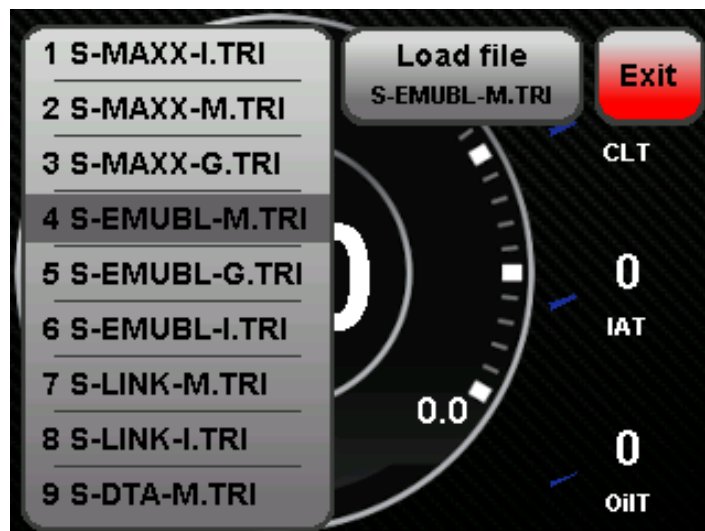

Figure 19: TRI/TRX Selection Submenu

Now you can select your engine code/ECU from the list and by clicking on the corresponding file the name of the file will be transferred to the *load file* button. Now you can press *Load file* to load and activate the *TRI/TRX file*.

If you can't find your engine code or ECU in the list, there can be two different reasons:

- There is the wrong firmware on your data display, so that the files of the *desired protocol* are hidden (see chapter 6.2)
- The desired *TRI/TRX files* are not on your SD card and must be added later.

You have two options for adding the files to your data display:

1. Remove the SD card from the display, insert it into a computer and then copy the *TRI/TRX files* to the "can" folder on your SD card.
2. Establish a USB connection to the display and load the files onto the display via *the DSS* .  
More information can be found in chapter 9.6

No matter which of the two ways you choose, you have to select the *TRI/TRX file* on the display as described above.

## 7 Adjust on the display

While with the Gen1 CANchecked data displays almost everything could be configured on the display, the possibilities to set up the sides on the display itself have been significantly reduced with the Gen2.

To improve the setup of your data display, we've put even more work into customizing your display using *DSS*.

Nevertheless, you can adjust your data display a little even without a PC. Not all Widgets described in chapter 9.3.2.3 can be configured on the display. Which widgets you can customize on the display and what you can change with them can be seen in the table below.

Before that, the page must be unlocked in *the setup* under *pages*.

Table 4: On the display customizable Widgets

<b>Widget</b>	<b>Possible changes</b>
<i>vertical bar</i>	MinValue, MaxValue, zugeordneter <i>Sensor</i>
<i>round meter</i>	MinValue, MaxValue, zugeordneter <i>Sensor</i>
<i>YT diagram</i>	Zugeordneter <i>Sensor</i>
<i>sensor range</i>	Zugeordneter <i>Sensor</i>
<i>G-meter</i>	MaxValue
<i>Tire temp</i>	MinValue, MaxValue, zugeordneter <i>Sensor</i>
<i>horizontal bar</i>	MinValue, MaxValue, zugeordneter <i>Sensor</i>
<i>needle</i>	MinValue, MaxValue, zugeordneter <i>Sensor</i>
<i>theverlay</i>	MaxValue, zugeordneter <i>Sensor</i>
<i>performance meter</i>	Zugeordneter <i>Sensor</i>

It is not possible to change the size or position of widgets on the display. This requires a connection to the *DSS*.

When changing the widgets on the display, it is very important to check how many widgets are on top of each other at this point before changing them. To do this, you can dig a layer deeper into the user interface with each click on the display. For example, the *predefined page TrackView* has five layers on top of each other, while the *DailyDash* has three layers.

In the event of a change, attention must be paid to the selection of the correct *widget*. As soon as the first *widget* is selected, it is marked by a red box. The lower part of the display now shows which *widget* it is. If you click OK you close the edit mode, you tap again on the corresponding place and your display switches through to the next layer. You can click until the selection fields for the possible options are gone again, now you are through all layers and can start all over again.

In the image below, the three layers of the *DailyDash* are visible.

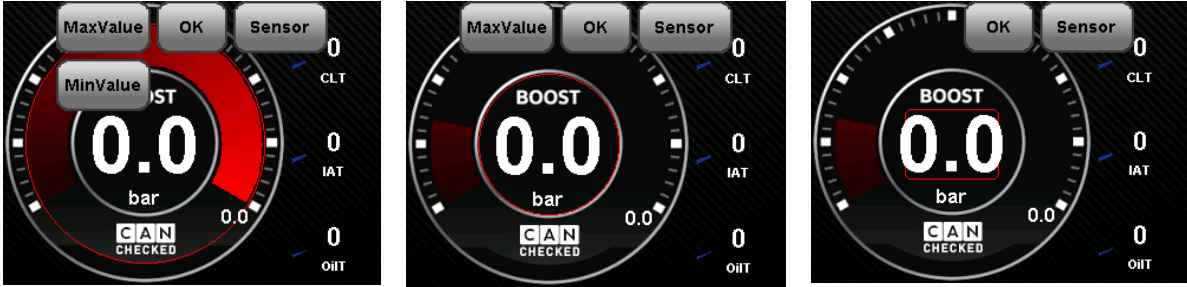

Figure 20: The three layers (round meter, overlay and sensor value) on the *DailyDash*

With the *DailyDash* are not only three layers above the large boost pressure display, but also above the three small round displays arranged on the side. If a *sensor* is changed here, it must be adapted for all three *widgets*.

## 8 Flashing the firmware

To change or update the firmware installed on your display, you must use our CANchecked Updater. You can find it on our website under Downloads MFD28/32/32S (<https://www.canchecked.de/downloads/mfd28-mfd32-mfd32s-mfa28-update-softwareaktualisierung/>). The updater is available for Windows and Mac.

**ATTENTION:** Windows 7 still requires a **driver**. This can also be found in the MFD28/32/32S download area.

After unpacking and starting the updater, you should find the user interface shown in the image below.

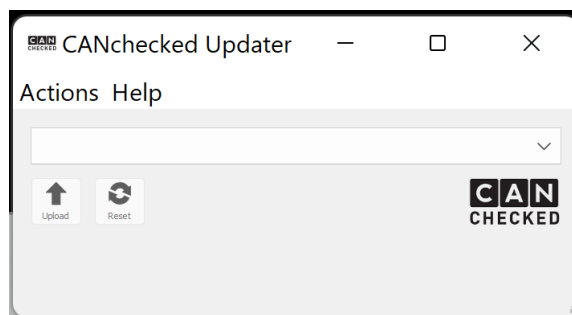

Figure 21: CANchecked Updater

After inserting your display, your PC/Mac should recognize the display and automatically identify it as an available device in the updater and display it as a serial USB device.

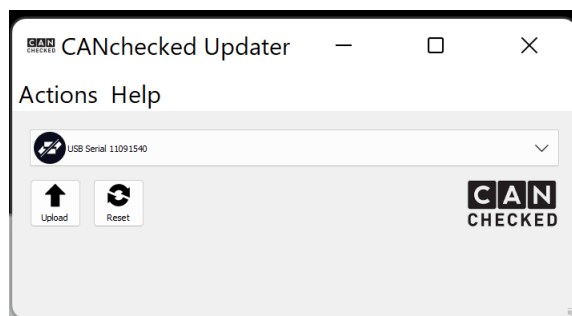

Figure 22: CANchecked Updater with connected display

Before you can start updating your display, you need to download the appropriate firmware from our website. In the download area you will always find the latest version for your display. Here you can find the right firmware (6.26.2).

For your Gen2 data display, the firmware has the following format:  
CANchecked\_v4.XXX\_[protocol].hex

By clicking on the corresponding firmware, you can download it to your PC/Mac.

If you have downloaded the firmware to your PC/Mac, you can now continue in the CANchecked Updater. By clicking on the upload button in the CANchecked Updater, the folder structures can now be searched. Now navigate to the directory where you saved your firmware, select it with a mouse click and press Open. In the CANchecked Updater, a green loading bar now runs through the user interface and the display restarts (exception when installing an init file\*, here the display only starts again after installing a regular software).

*\*Must only be installed when the data display is no longer accessible and must be requested by technical support ([info@canchecked.de](mailto:info@canchecked.de)) if necessary, please send a description of the problem situation and development*

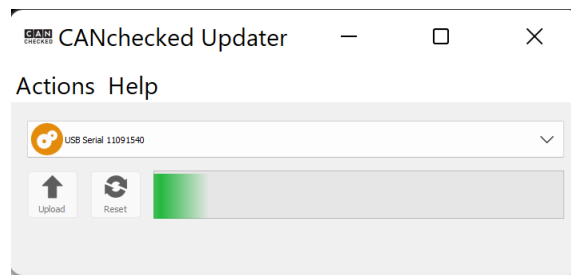

*Figure 23: CANchecked Updater with loading bar during the update*

As the charging bar passes through, your PC/Mac will hear the sound that comes out when the USB connection is disconnected and restored. Then your display reboots regularly and is now ready for use again.

## 9 Customizing the display on the PC with the DSS

To make your data display unique, you can't avoid our *DSS*. You can download the *DSS* for free from our website at [www.canchecked.de/dss/](http://www.canchecked.de/dss/). This is available for both PC and Mac. On our website you will find a quick guide to download and install. Furthermore, you can find the **driver** required for **Windows 7** here. As soon as you have installed the *DSS*, you can execute it, should be able to see the following start screen and click on the CANchecked logo to get to the selection field of the device to be connected.



Figure 24: DSS startup

Here you click on the selection field for Gen2 devices (right) and now get to the tab overview. The following tabs are available:

- *Connection*
- *TRI Editor*
- *Pages*
- *Log Viewer*
- *Other settings*
- *Upload*
- *Can log*

Basically to **avoid problems**, we strongly recommend always establishing a connection to the display and **not** working offline.

## 9.1 Connection

To connect to your data display, you have to click on the *Connection* tab in the tab overview.

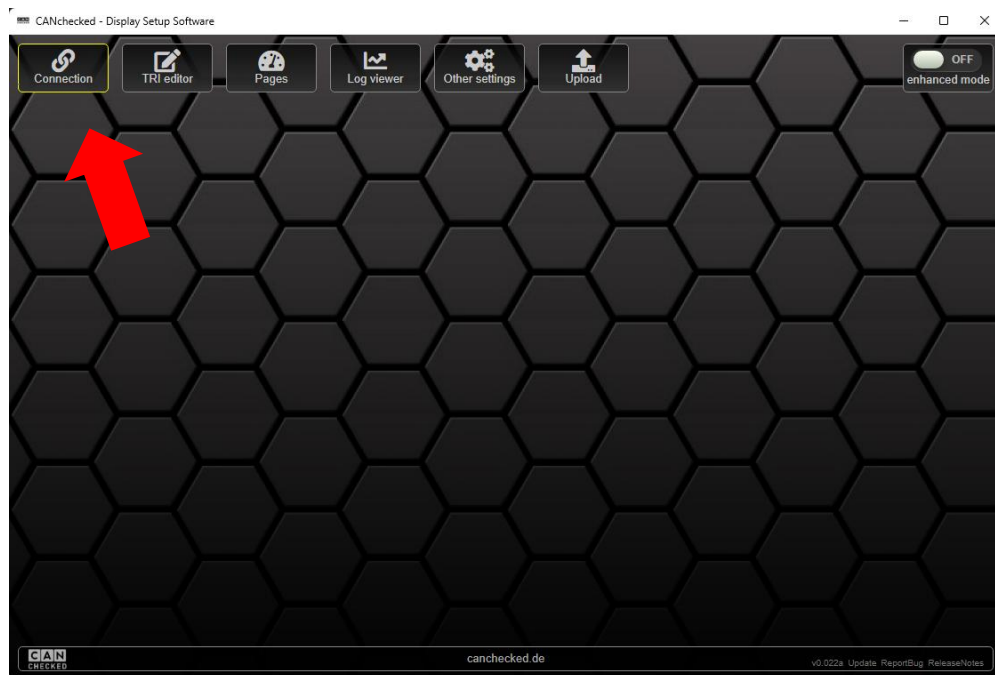

Figure 25: DSS tab overview

By now at the latest, you should have connected your data display to your PC/Mac via USB. If this is the case, you can select the data display as an available COM port from the list on the left side of the screen and establish the connection by clicking on it.

**Attention:** After **plugging** in the USB cable, please **wait until** the **start animation** has **run through** on the display before the connection is established in the *DSS* to avoid a disconnection. The display is supplied with power via the USB cable. You can leave the ignition switched off.

If you have several COM ports to choose from, please try which port your display uses to communicate with the PC/Mac. If you have found the right port you will get connected OK as a message and the frame around the connection tab will turn green and the import of the pages will start. During the import of the pages your display automatically switches through all pages. The connection and the loading of the pages can take up to one minute.

If you have previously activated the enhanced mode in the upper corner, a popup opens to deselect certain import functions. More about this mode in chapter 9.2.2.

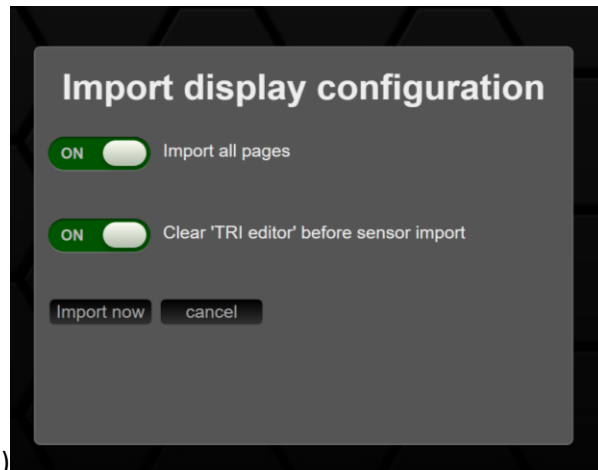

Figure 26: Importing the Display Configuration

If the slider is set at the first selection field, all pages of your data display are actively imported into the DSS.

Only if this slider is active, you can call up an overview of all pages in the Pages tab. More about this in chapter 9.3.

If the slider for the second selection field is active, the TRI Editor is emptied before the sensors are imported from the data display. Caution: Only deactivate this slider if you know what you are doing. If the slider is deactivated, it can happen that there are duplicates in the TRI Editor and in the worst case you make your TRI/TRX file unusable.

Since firmware 4.007c, you can save the complete display configuration in the *connection* tab. Currently, this function is only used internally and for root cause analysis. The installation of other display configurations is planned for the future.

## 9.2 TRI Editor

In the *TRI Editor*, all sensors of your data display can be found after the import. In addition to the *sensors* that come as can messages on your display, you can also create and parameterize the four analog inputs here.

**Attention:** When the display is fully set, the position of the sensors in the *TRI/TRX file* should not be changed by deleting or moving, as this refers to the position of the *sensors* in the *sensor init* and on the *pages*.

### 9.2.1 Handling

Below the tab overview you will find the buttons of the *TRI Editor*. The button is divided into four sections.

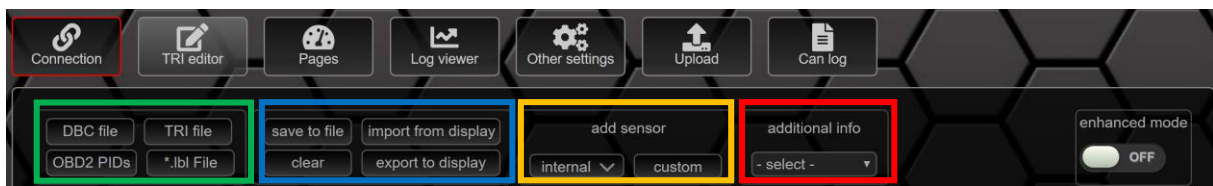

Figure 27: Buttons in the TRI editor

In the **first area**, you can import *sensors* from different data formats into the *editor*. Possible formats are:

- DBC Files
- TRI Files
- OBD2 PIDs
- \*.lbi Files

In the **second area** you will find the function buttons for saving the TRI file currently loaded in the TRI Editor, the command to delete the *sensors* from the TRI Editor as well as the buttons for importing and exporting the TRI file from or to your data display.

The **third area** can be used to add *internal* and *custom sensors*. The *internal sensors* include:

- *AIN1*
- *AIN2*
- *AIN3*
- *AIN4*
- *AIN5 (only for MFD15 Gen2)*
- *AIN6 (only for MFD15 Gen2)*
- *displayVolt*
- *displayTemp*
- *PWMoutDuty*
- *GearCalc*
- *FreqIn1*
- *MathChannel1*
- *MathChannel2*
- *MathChannel3*
- *MathChannel4*
- *MathChannel5*
- *MathChannel6*

- *MathChannel7*
- *MathChannel8*
- *Ustable1*
- *Ustable2*
- *Ustable3*
- *Ustable4*
- *Ustable5*
- *Ustable6*
- *Ustable7*
- *Ustable8*

The **fourth area** can be used to get a quick overview of the individual information about the *sensors*. Simply select the desired information and compare it directly.

To set the *min* and *max warning values* for each *sensor* in the *TRI* click on the corresponding *sensor* to open the popup for editing.

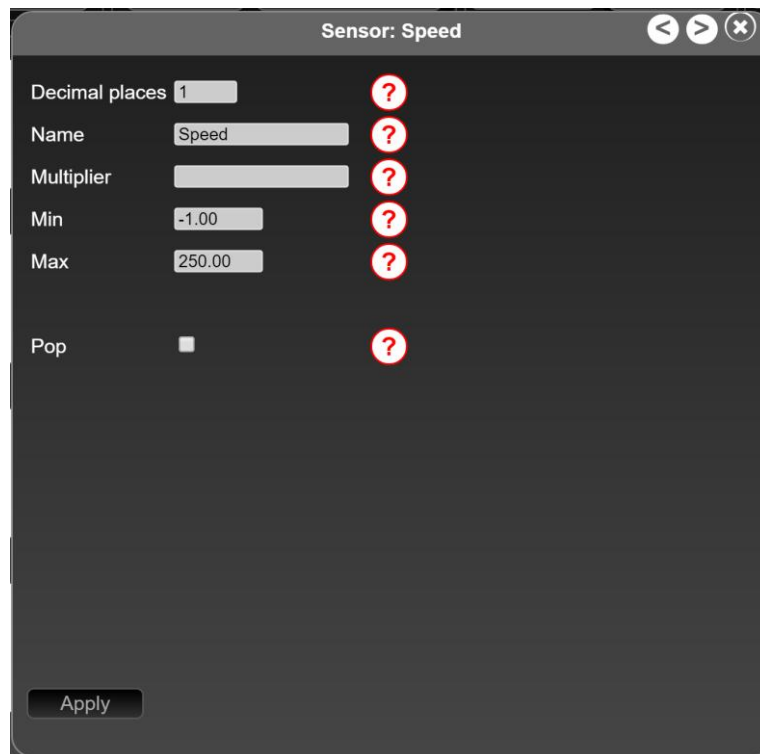

Figure 28: Popup to Edit the Sensor in Normal Mode

In addition to the *min* and *max* warning values, you can also assign/change the names of your *sensors* (*maximum 15 characters – no special characters*) and switch popups for the *warning values* on and off. After you have changed/renamed the sensor, you have to confirm the changes with the *Apply button*. Once you have adjusted all *sensors* according to your wishes, you can transfer the changes to the data display via the *export to display* button on the button.

### 9.2.2 Global enhanced mode

The *enhanced mode* can be found in the upper right corner of the button bar. If this is not active, the pages and sensors can only be configured in a rudimentary way, and the Can Log tab is not available.

As long as the enhanced mode is deactivated, you cannot add new widgets to the pages and configure them only in the sensor mapping. The following subchapters describe the possibilities when enhanced mode is activated.

If you switch on the *enhanced mode*, you get even more possibilities to configure your sensors and the associated Can Bus details and reference sensors.

With the reference sensor, you can set the min or max warning even better. For example, if you set a min warning of 1.1 bar for the oil pressure, you will constantly get a pop-up even when idling. If you now specify the sensor speed as *RefSensor* with a *RefValue* of 3000, the min oil pressure warning will only be activated if the oil pressure is less than 1.5 bar, but only as long as the *sensor* speed has a value above 3000.

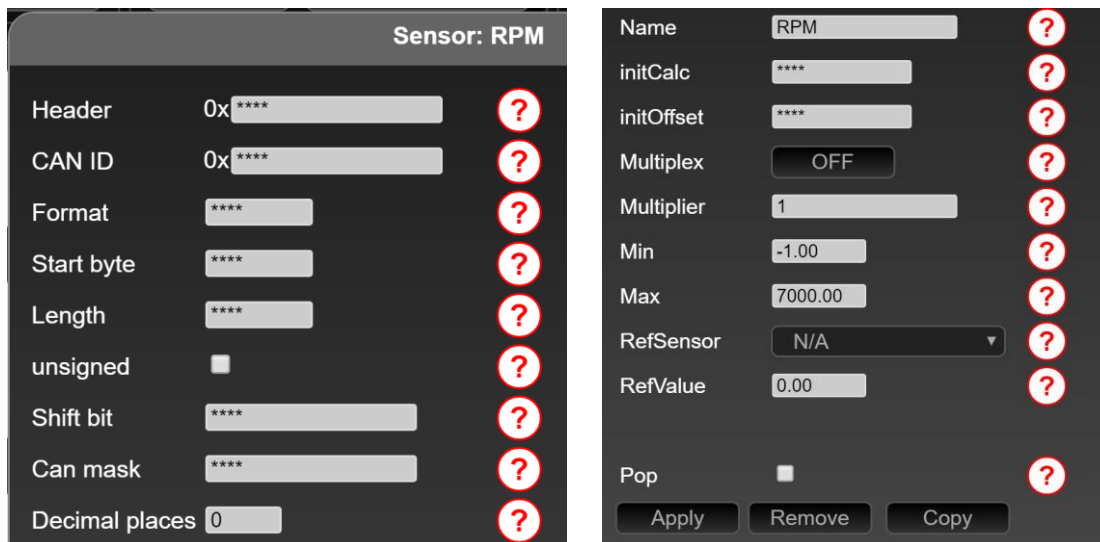

Figure 29: Popup for editing the sensor in enhanced mode

In addition, you now also have *the remove and copy* buttons to choose from with which you can delete, and copy can address and sensors. This function is especially handy when creating your own *TRI files*.

Please note that the pages point to the *sensor's* location, so if you delete *sensors*, you will most likely need to readjust your pages.

*TRX files* are only partially editable in *enhanced mode*. Encrypted values are marked with "\*\*\*\*" and should not be edited.

### 9.3 Pages

In this tab you can adjust the individual *pages* of your data display. If you have ticked both boxes when establishing the connection, you will get an overview of all pages created on your data display by clicking on the *Pages* tab and can also switch from here to the individual view of the pages by clicking on them. In addition to hiding individual pages in the display setup on the data display itself, you can also hide or make visible the pages in the overview page by ticking the box.



Figure 30: Pages overview page with hidden pages

If the check mark for loading all pages was not set when connecting, you will land directly on the single view and must manually load the currently active page into the *DSS* by clicking on *import from display*.



Figure 31: Pages single view with button

**Attention:** If your data display is connected to the *DSS*, it is no longer possible to change the *pages* on the display by swiping gestures. When the connection is active, the pages can only be switched through by pressing the **arrows** in the single view. You can see which page is currently active by the small number below the *import to display* button.

Further functions in the single view are:

- *export to display:* Writes the currently loaded/created page in the *DSS* to your data display
- *load from file:* Imports a preconfigured page from another source
- *save to file:* Saves the currently loaded page to a location of your choice
- *helper lines:* Projects auxiliary lines into the *DSS* for easier **arrangement of widgets via drag and drop**
- *clear view:* Deletes the currently loaded page in *the DSS* and lets you start on a blank screen
- *load predefined page:* Here you can load preconfigured **pages** into the *DSS* with one mouse click and then write them to your data display via *export to display*

Below the load predefined page button, you will find a *Animate* slider. With this slider you can activate the *demo mode* (see chapter 5.12) from the *DSS* and then see how the *widgets* behave during operation. When positioning your widgets, please pay attention to the position on the data display as the positions in the *DSS* preview are not 100% accurate.

**After changing your pages**, please always remember the **export to display** feature before your hard-earned changes end up in nirvana.

### 9.3.1 predefined pages

We are constantly expanding our *predefined pages*. By clicking on the *load predefined page* button, you get the names and a preview of the corresponding pages displayed and can load them into the DSS by double-clicking. So far, you can choose from these views:

- AirflowLogging
- BasicLogging4cyl
- BasicLogging5cyl
- BasicLogging6cyl
- BasicLogging8cyl
- DailyDash
- DPFinfos
- DriverDynamics
- FuelLogging
- Keypad
- MaxxECU
- Overview
- PerformanceMeter
- RPMBar
- TrackView
- TuneDisplay

### 9.3.2 Widgets

To the right of the preview of the page, you'll find the list of *active widgets* on the page. The smaller the number of the *widget*, the further it is in the background. For example, *widget 5* is always above *widget 4*. Typically, *widgets 0* and *1* are smaller logos or backgrounds.

You can arrange the individual *widgets* in the list by **dragging** and move it to the desired layer.

If you select a widget in the preview, the corresponding widget is marked with a red + in the list of active *widgets* and the submenu for the *widget* opens. If you click on the red symbol again, the submenu will collapse again. The individual submenus and widgets explained in the following chapter.

If you uncheck a widget in blue, the widget will be made invisible in your preview in the *DSS*. You can use this function to create *widgets* in different layers in the same place without accidentally clicking on it.

In addition to the number of the widget, you can also see at a glance what kind of *widget* it is. In addition, you can see in square brackets which *sensor* or image is assigned to this *widget*.

If something is unclear during setup, you can always press the red circle with the question mark to get more information about the corresponding widget or setup.

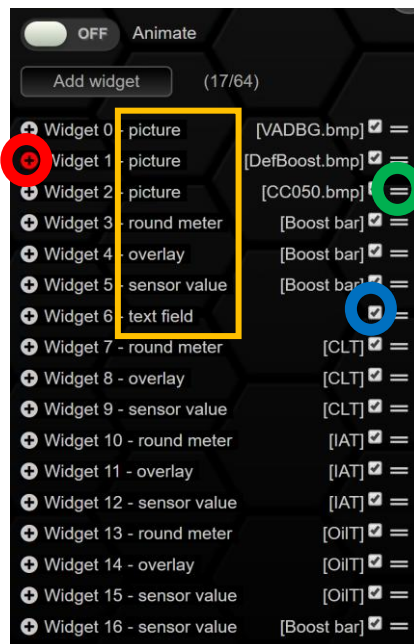

Figure 32: List of Active Widgets

Use the *Add widget* button to add a new widget to your site and then select which widget it should be from the drop-down menu. Once you've added a new *widget*, you can drag and drop it onto your page. The different ways of configuring the *widgets* (submenus) are discussed individually for each *widget* below.

### 9.3.2.1 General

In the display options of your *sensors*, you can choose from 20 *widgets* to have all important information at a glance. In the following, each and the configuration options of the *widgets* within the *DSS* are explained.

In general, almost all *widgets* can be changed in their position, color and size. The position and size are given in X and Y coordinates. The coordinate system is visible in the preview next to and below the preview window. The coordinate origin is in the upper left corner and corner. The bottom right corner has the coordinates 320/240. You can either drag and drop individual *widgets* with the mouse or select them with the mouse and then arrange them with the arrow keys.

Depending on the type, a *sensor* must be assigned to the *widget*. When creating a new *widget*, the first *sensor* of the currently loaded *TRI/TRX file* is always selected. To delete a *widget*, it can be deleted after selection by pressing the *Delete widget* button. A maximum of 64 *widgets* can be created per page.

For easier arrangement of the *widgets*, the Grid lock function can be used. This is located at the bottom of the preview window. If the function is activated, the *widgets* automatically snap into place for easier arrangement. A good starting value for this feature is 20 pixels.



Figure 33:Auto Grid lock

### 9.3.2.2 Color selection

For most widgets, you can configure the colors. Color gradients, font colors and background colors are freely configurable. The color wheel shown in the figure below is used to adjust the colors. In the outer circle you specify the base color, in the inner square the brightness or darkness. The color is then always written as hexadecimal code in the corresponding field of the widget and can be marked and copied here to be applied to other widgets.

**Special feature:** If the colour of the background (**bg colour**) is identical to the colour of the font (**font colour**), the background becomes **transparent**.

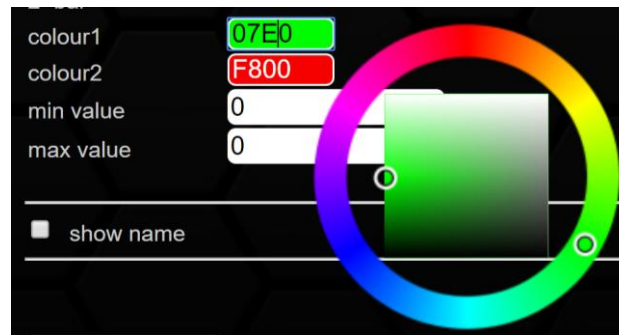

Figure 34: How the Color Picker Works

### 9.3.2.3 vertical bar

The vertical bar is a vertical bar chart and can be used wonderfully to display and compare temperatures or pressures. This is freely configurable in both size and color. A gradient is also possible.

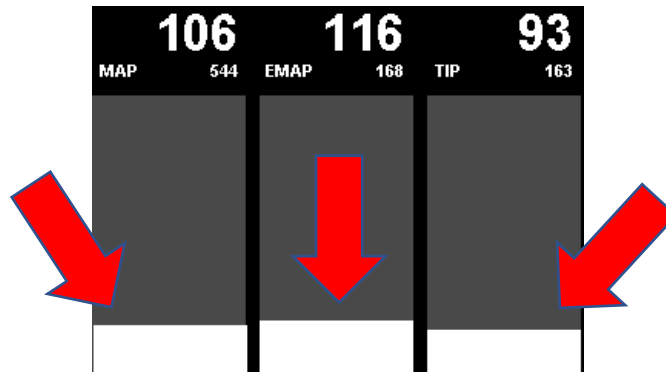

Figure 35: Display view of the vertical bar widget for comparing three pressures

When it comes to the course of the *vertical bar*, you can choose from three options:

- Ascending from bottom to top (*bottom2top*)
- Falling from top to bottom (*top2bottom*)
- Horizontal line as pointer (*bar*)

Furthermore, a colour for the lower values and a colour for the upper values can be defined. For optimal design of the display area, the lower or upper limit of the *vertical bar* can be set at *min value* and *max value*. If these limits are set to 0, the values of the corresponding *sensor* from the *TRI/TRX file* are used.

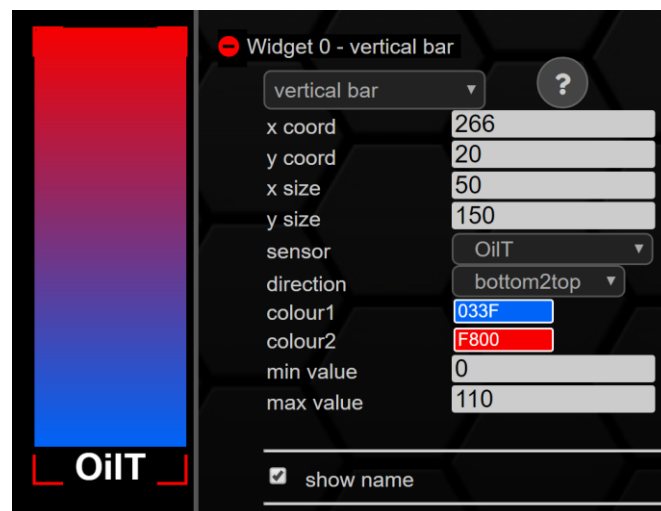

Figure 36: Configuration vertical bar

In the previous example, the sensor was assigned to *OilT*. Thus, the *vertical bar* is blue first and then turns red with increasing oil temperature.

If the check mark is set at *show name*, the name of the assigned *sensor* is displayed in the lower area of the *vertical bar*.

Since 4.007c, the vertical bar can also be set with an angle.

### 9.3.2.4 round meter

The *round meter* is a classical display, which is already known from the Gen1 CANchecked data displays. Different sizes and color gradients are possible here. In the figure below, one large and four small *round meters* with different color gradients are visible. The central value does not belong to the *round meter* widget but is a separate *sensor value* widget.

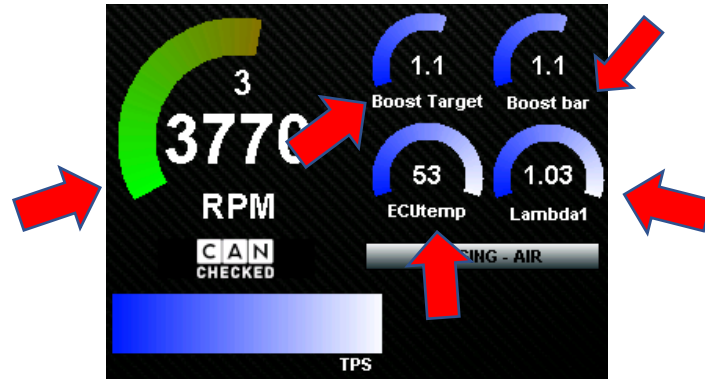

Figure 37: Display view different round meters

As with *vertical bar*, the color gradient of the *round meter* can also be adjusted. The name can be changed in size and position (*offset*). As with the *vertical bar*, the *min value* and *max value* functions can be used to set the values for the start and end of the *round meter*.

The position of the start and the end can be adjusted in angles, where 12 o'clock stands for 0 degrees. -120 degrees is eight o'clock and 120 degrees is four o'clock. The *ghost time* function can be used to generate a split-seconds pointer. With this, the pointer stops for a few milliseconds after the peak and facilitates readability during operation.

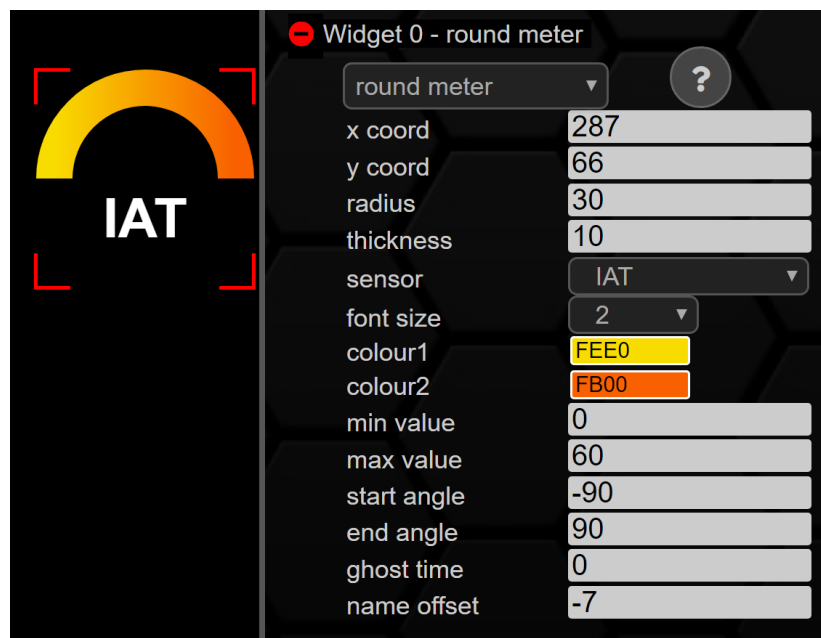

Figure 38: Configuration round meter

In the example shown above, the *sensor* IntakeT was assigned to the *round meter*. The scale here only extends from nine to three o'clock with minimum and maximum values of 0 and 60 degrees.

### 9.3.2.5 YT diagram

The *YT diagram* is also known from the Gen1 data displays. With this widget you can display the history of a sensor value over time. Ideal for a direct overview of the peaks of your sensor readings after a pull.

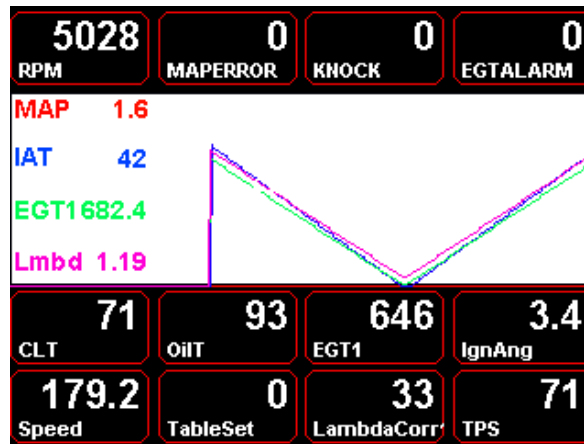

Figure 39: Display view of a YT diagram with four graphs

The chart can be varied both in size and position. Only one *sensor* can be assigned to each diagram. If several *sensors* are to be displayed simultaneously in one window, several *YT diagram widgets* must be superimposed.

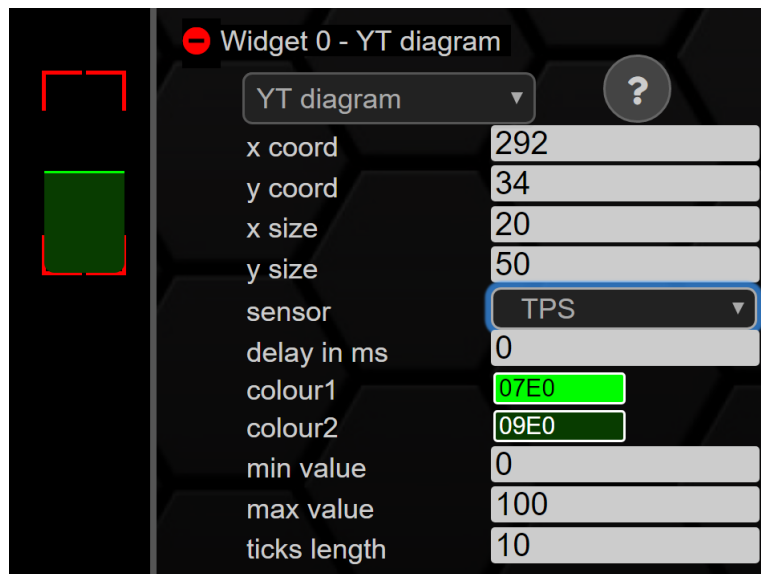

Figure 40: Configuration YT diagram

A delay can be implemented (delay in milliseconds). Furthermore, the color of the graph and the underlying surface can be configured. If the **two colors are identical**, the underlying surface becomes **transparent**. *Min value* and *max value* specify the lower and upper bounds of the y-axis, respectively. With *ticks length* you can set a small mark every X pixel to better divide the X-axis.

### 9.3.2.6 Enumeration

With the *enumeration widget* you have the possibility to display numbers in text. So, you can display error codes in plain text. For example, a "1" received via the Can Bus could be shown on the display as "No errors deposited". A "2" received via the bus, on the other hand, could mean "engine malfunction – check engine". A gear display can also be realized via this. For the corresponding representation, a text must be assigned to each possible number.

Like all other widgets, you can adjust the position and size of the widget via *x coord*, *y coord*, *x size* and *y size*. You can adjust the size of the displayed plain text via the *font* function. Here you can set font sizes from 0-9, where 0 is the smallest and 9 is the largest. As with other widgets before, you can set the font color via *colour*. In the following illustration, the *enumeration widget* is used to display the states of the EGT alarm.

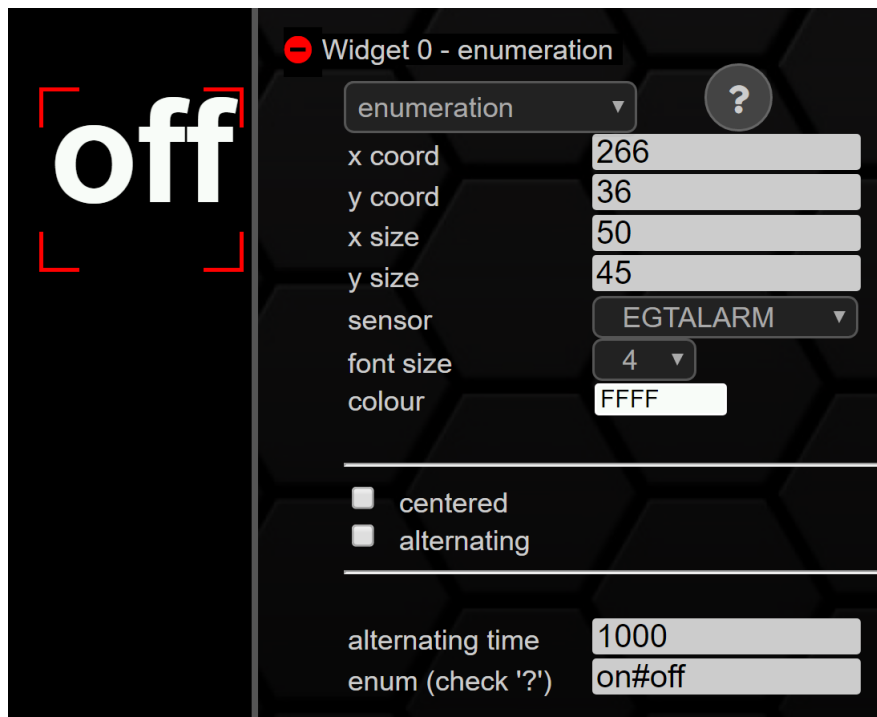

Figure 41: Configuration enumeration

The status is displayed right aligned by default, if the check mark is set at *centered*, the text is displayed centered. The alternating function switches between the individual plain texts if several are active at the same time. *Alternating* time determines the time to switch in milliseconds. In the *enum* field, the corresponding plain texts can be entered with a hash as a separator. If no value is to be displayed as an enumeration, a space must be set (State1# #State3).

### 9.3.2.7 Icon

The *icon widget* can not only be used to beautify the pages and make them look more appealing. Rather, it can also be used to concisely display the states of sensors. For example, a red icon can signal that a certain pressure or temperature has been exceeded or undercut. There are no limits to your imagination, and you can choose from a variety of predefined icons. The icons can be changed in size and color. In the image below you will find a small selection of the possible icons.

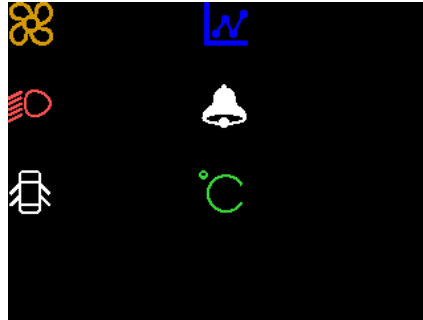

Figure 42: Display view with selection of icons in different colors

Similar to the *enumeration* and *status rectangle widget*, states of *sensors* can be mapped here using logical operators (`==`; `>`, `>=`; `<`; `<=`).

To beautify the pages, the same color must be assigned to both states, so that the *icon* is displayed permanently and independently of *sensor* and status. If a 0001 is entered at colour, this state becomes transparent.

Like the other *widgets*, the *icon* can be changed in size and position. The size of the *icon* itself is not set via *x* and *y* size but via *font*. *X* and *y* size only change the size of the *widget's* frame so that it can be clicked better or worse in the preview.

In the following example, the *icon widget* is used to monitor the state of the oil pressure. If the oil pressure is less than the value entered in value, the oil can will flash red, if the value is greater, the oil can will flash green.

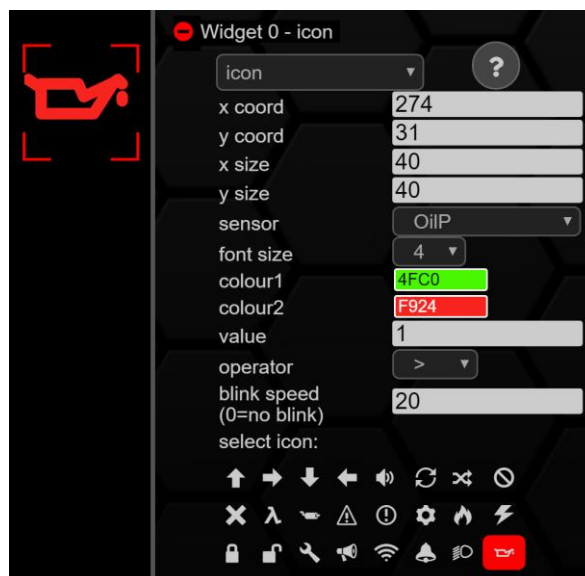

Figure 43: Configuration icon

### 9.3.2.8 sensor value

With the *sensor value widget*, you can display a sensor value as a simple number. The number of decimal places is specified by the *TRI/TRX file0*

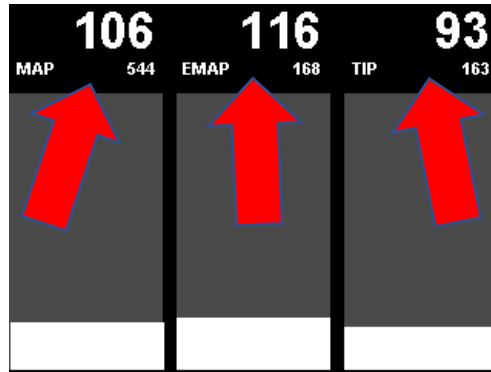

Figure 44: Display view for comparing pressures using the triple sensor value widget

If you like a frame around the widget better, you can also activate it and adjust its color. A representation of the optics can be found below.

Exceeding the max value (red background) or falling below the min value (blue background) can also be activated individually for the widget.

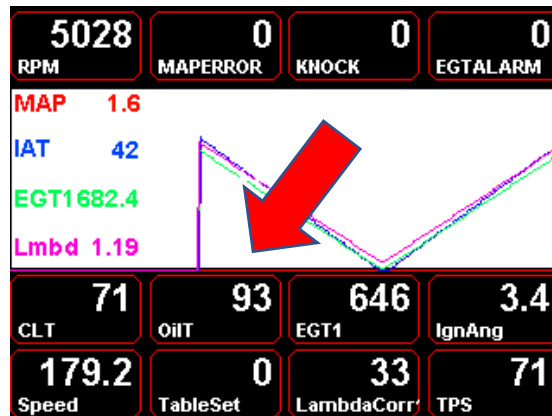

Figure 45: Display view of the sensor value widget with frame

You can adjust the numerical value in font, position, *font colour*, *bg colour* and *frame colour*. As with the YT diagram, the background becomes transparent if the three colors have the same color.

In addition to the previously mentioned options, you can now also edit the display type of the sensor value. Here you can choose between normal numbers (Font 1) and 7-segment numbers (Font 2).



Figure 46: Font 1

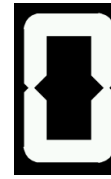

Figure 47: Font 2

The functions *low warn colour* and *high warn colour* refer to the min and max values from the TRI/TRX file if the min or max value from the TRI/TRX file is below or exceeded, the entire box (*x/y size*) of the *sensor value* colors in the color you selected.

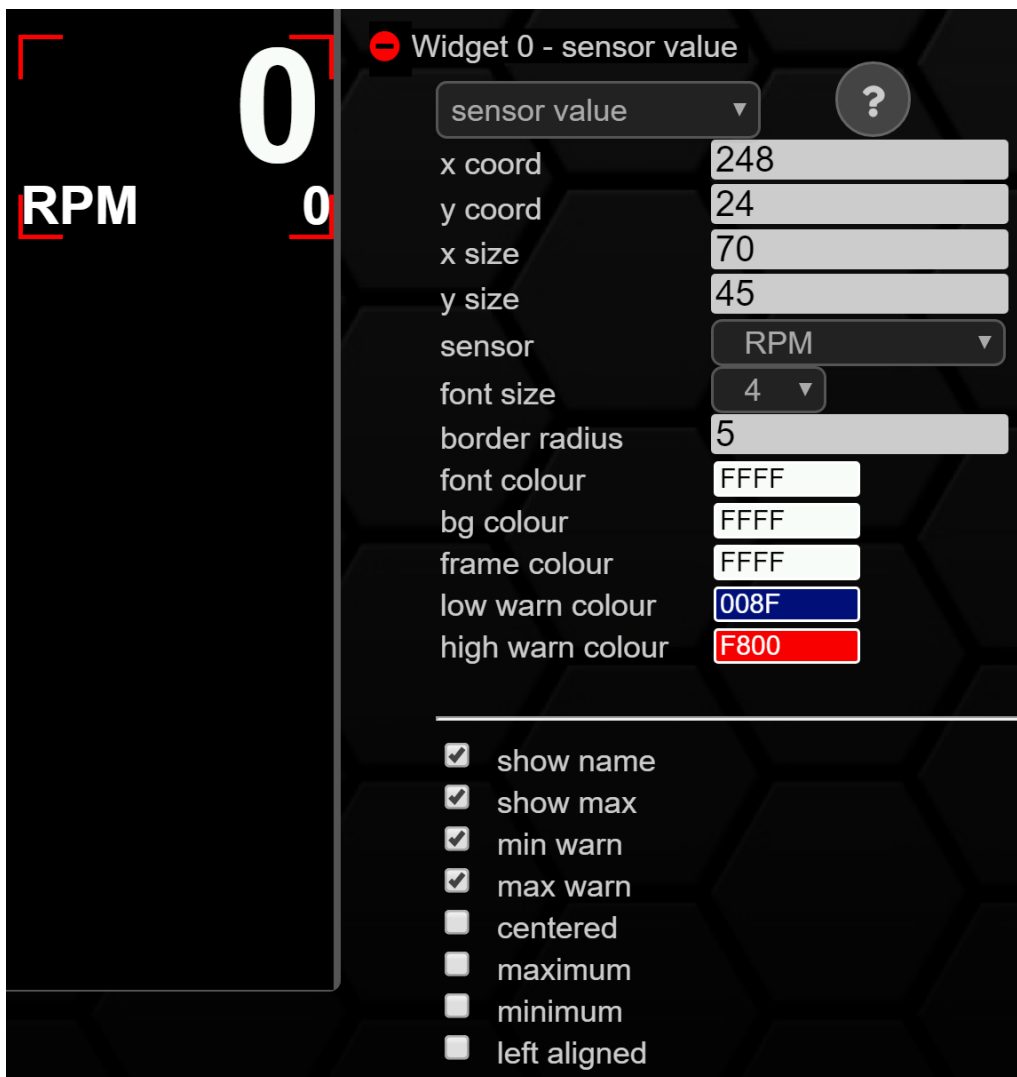

Figure 48: Configuration sensor value

By setting/removing the checkmarks, you can personalize your *widget* even further.

- *show name* -> shows the name of the associated *sensor*
- *show max* -> displays the maximum value of the current session as a small numerical value below the measured value one

- *m in warn min value* -> activates the color set at *low warn colour* when falling below the in the *TRI/TRX file*
- *max warn* -> activates the color set at *high warn colour* when the *max value* is exceeded in the *TRI/TRX file*
- *centered* -> centers the measured value within the frames (*x/y size*)
- *maximum* -> hides the current measured value and displays the maximum value of the current session
- *minimum* > hides the current measurement value and displays the minimum value of the current session
- *left aligned* -> moves the measured value within the frame lines to the left (*x/y size*)

### 9.3.2.9 Gear

With the *gear widget* you can display the currently engaged gear as a large number. The *gear widget*5.5TrackView.

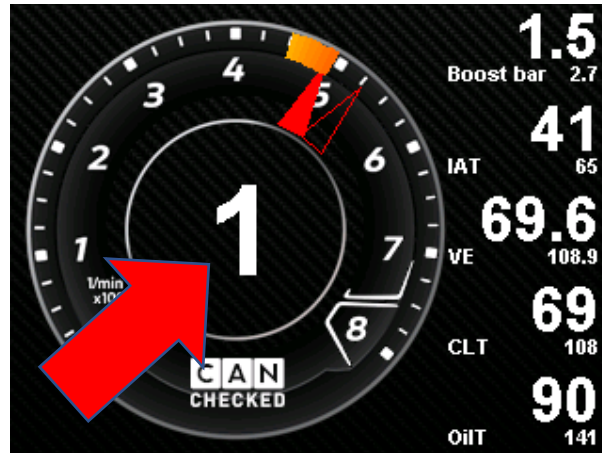

Figure 49: Display view of the gear indicator in the rev counter of the TrackView

In automatic vehicles, the display of the gear (P; R; N; D; S).

Important for the error-free function of this *widget* is the correct assignment of the *sensors* in the *sensor init*. 5.3If *gear mode* is not assigned in the *sensor init*, only the gear is displayed. As shown in the image below, you can customize this *widget* in size, position (*x/y coord*), and font color. As with the other *widgets* before, *x/y* size only affects the size of the surrounding box and not the display itself.



Figure 50: Configuration gear

### 9.3.2.10 Timer

The timer widget starts and stops by pressing a button on the display. The current and the 4 best times are displayed. As shown in the following illustration, you can adjust the size (*font*), position (*x/y coord*) and *font color*(*font color*) of this *widget*. As with the other *widgets* above, *x/y size* only affects the size of the surrounding box and not the display itself.

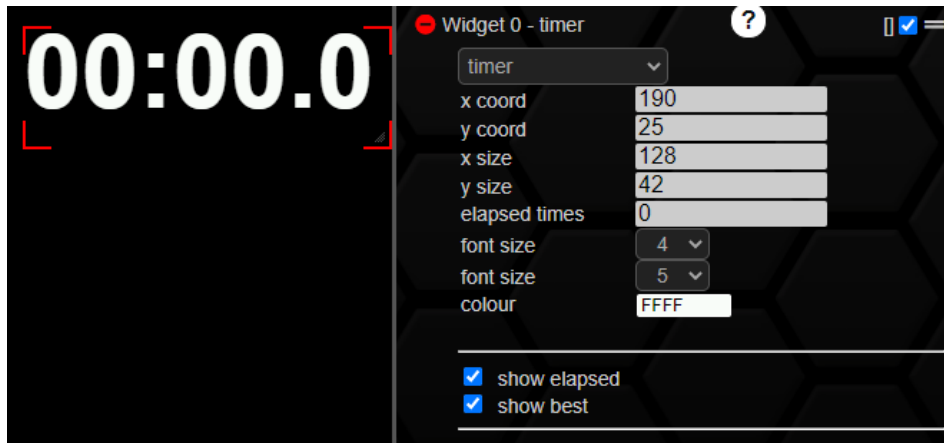

Figure 51: Configuration Timer

### 9.3.2.11 Tire temp

You can use the *Tire Temp* widget to graphically display the temperatures of our Tire/brake Monitor sensors. As shown in the figure below, you can adjust the size (*font*), position (*x/y coord*) and font color (*color*) of this *widget*. You can also set the number of *sampling points* to be used. Between *min* and *max value*, the colored field will change from green to yellow. Values smaller than *min* are displayed in blue, values larger than *max* are displayed in red.



Figure 52. Configuration tire temp

You can choose from 4 possible settings for the displays, whereby inverted inverts the order of the displayed sensors per widget:

- Tire regular
- Tire inverted
- Brake regular
- Brake inverted

You can view the illustrations of the widgets on the display below.

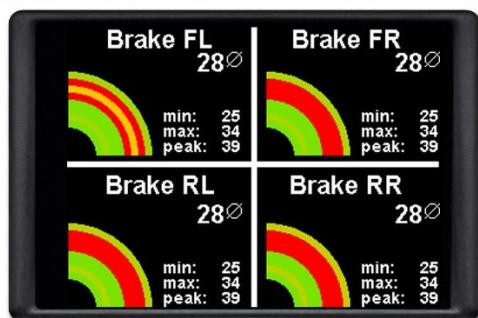

Figure 53: Brake

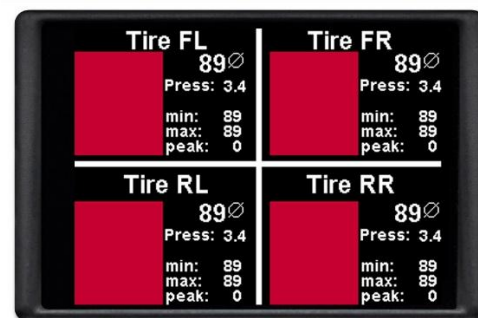

Figure 54: Tire

### 9.3.2.12 G-meter

The *G-meter* is a widget known from motorsport. The sphere shows you your longitudinal and lateral accelerations (unit: G). In addition, the maximum lateral and longitudinal accelerations achieved can also be displayed. Ideal for the next trackday to find the ideal line, just to improve your lap times or verify your aeromods.

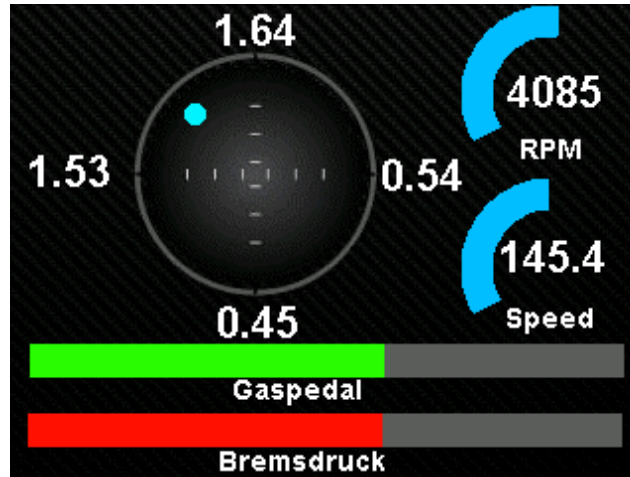

Figure 55: G-meter as predefined page

If your *TRI/TRX* file has the *sensors* for lateral and longitudinal acceleration, you can use the *Gmeter*. With this *widget* you can display the acceleration/deceleration in the four spatial dimensions. The widget can be changed in size and position (*x/y size*). In addition, the size (*circle size*) and color (*colour*) of the point as well as the maximum value (*max value*) of the acceleration can be adjusted.

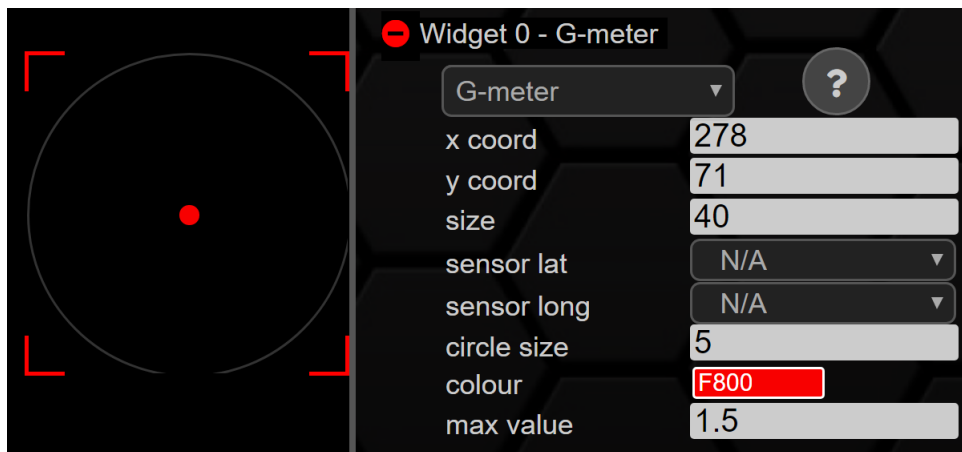

Figure 56: Configuration G-meter

### 9.3.2.13 can switch

The *can switch* widget is also already known from Gen1. With this widget you can save yourself a Can Keypad and use your data display as a keypad instead. Possible functions would be switching on and off additional devices such as pumps or fans or other hidden functions that you have integrated into your vehicle. The size as well as the colors of the switches can be freely configured. The figure below shows a switch. In this case, yellow is inactive and green is active.

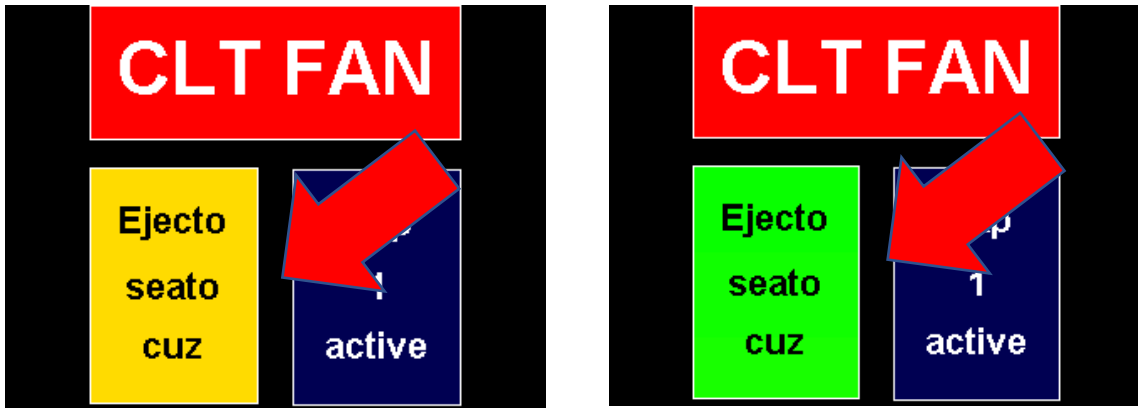

Figure 57: Keypad with two switches (yellow inactive, green active) and one multiswitch

If desired, a pop-up inform-window can be activated in the DSS when switching the switches. This then appears briefly when changing the state of a switch. Switches can be designed as both rasters and buttons.

The settings for the *widget can switch* are as with the other *widgets* also position (x/y coord) and size (x/y size). Use the *function can switch #* to enter the number of your switch.

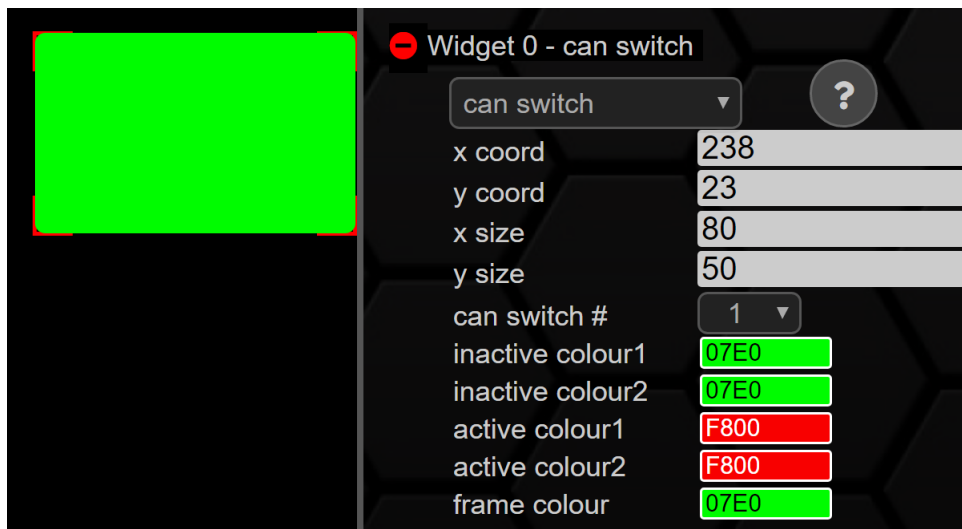

Figure 58: Configuration can switch

In addition, you can configure the colors of the two states (*inactive/active*) via the color wheel. For each status you can configure two colors, including a gradient and the color of the frame color.

### 9.3.2.14 multi switch

A *multi switch* is a switch that can assume two or more states. This can be used, for example, to switch different boost levels or to configure the control of the ABS. This function can be used to emulate a rotary potentiometer, for example, with your data display.

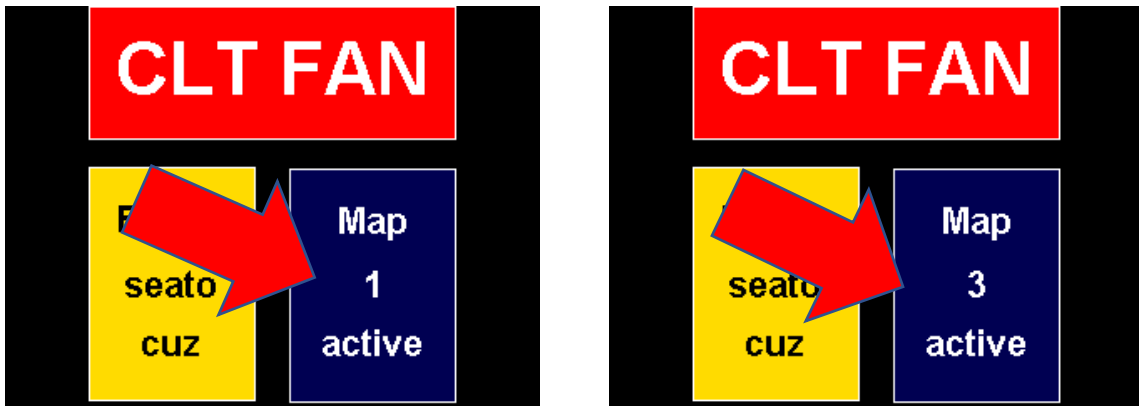

Figure 59: Keypad with two switches and one multi switch in different states

Like all other widgets, the Multiswitch is configurable in size and number of states with our DSS.

The *multi switch* can have up to eight different statuses. Like the can switch, you can also change the *multi switch* in position (x/y coord) and size (x/y size).

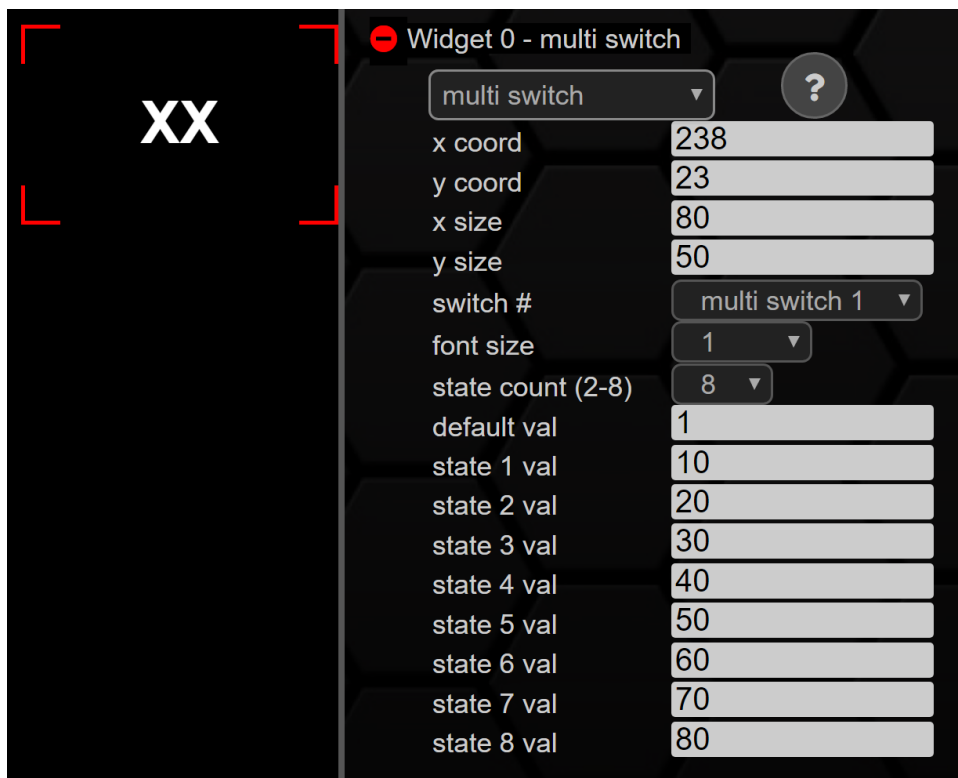

Figure 60: Configuration multi switch

You can create the number one to four and, to control the Haldex, a fifth multiswitch. *Font size* configures the font size, *state count* defines how many states the *multi switch* can accept. *Default val* the state when starting the displays and *state x val* the values of the corresponding states.

The last (fifth) multiswitch is for the Haldex widget. To do this, you first need a Haldex license. Contact your dealer to purchase a Haldex license for Gen1 and Gen2.

The sixth multiswitch is for a low-side output. You also need a licence for this. Contact your dealer to purchase a licence for Gen1 and Gen2 units.

### 9.3.2.15 horizontal bar

The *horizontal bar* is analogous to the *vertical bar*. The horizontal bar chart can also be used to display and compare temperatures or pressures. This is freely configurable in both size and color. A gradient is also possible. In the figure below, the widget is used to display the opening angle of the throttle.

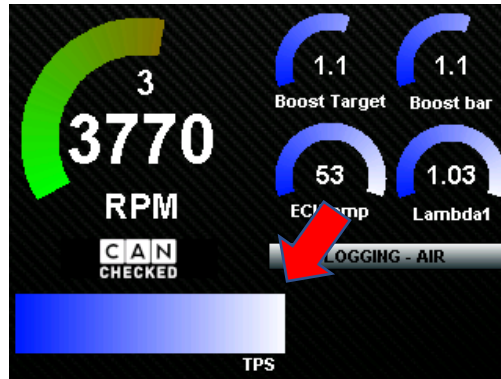

Figure 61: horizontal bar

With *the horizontal bar*, you can choose from three options:

- From left to right
- From right to left
- Vertical line as pointer

Furthermore, a color for the lower values and a color for the upper values can be defined. For optimal design of the display area, the lower or upper limit of the *horizontal bar* can be set at *min value* and *max value*. If these limits are set to 0, the values of the corresponding *sensor* from the *TRI/TRX file* are used.

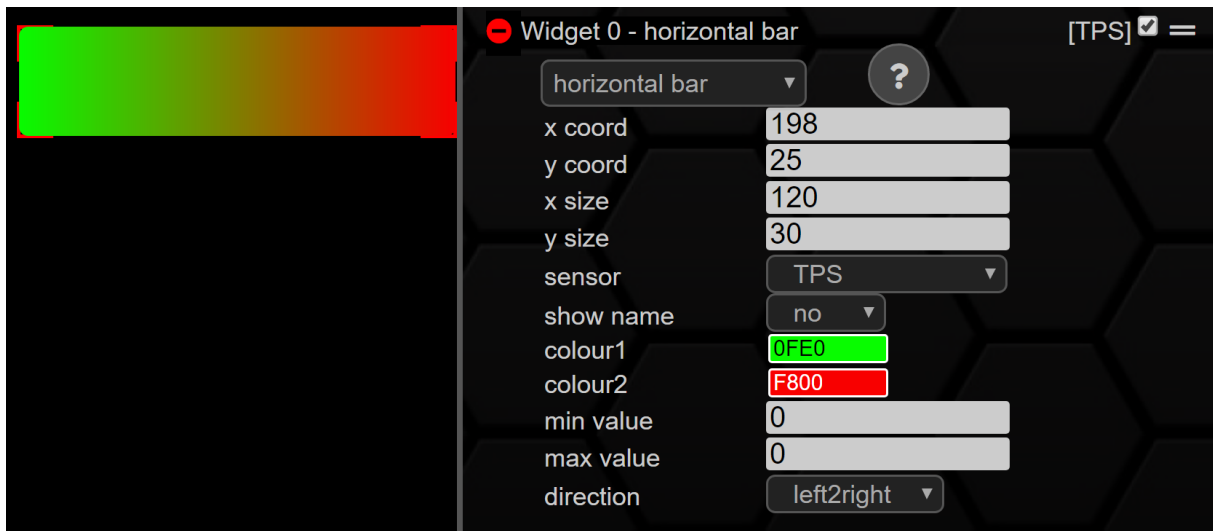

Figure 62: Configuration horizontal bar

In the previous example, the *sensor* was mapped to *TPS*. Thus, the *horizontal bar* is first green and then turns red with increasing throttle position.

At *show name*, the name of the assigned *sensor* can be displayed in the lower area of the *horizontal bar*.

### 9.3.2.16 Needle

The *new* widget can be used to configure your own analog pointer displays (rev counter/boost pressure indicator). The *needle* widget can be scaled with the *DSS* exactly to the desired size. Both the size and the color of the pointer are adjustable. In the screenshot below, the *needle* widget can be seen on the predefined *TrackView*.

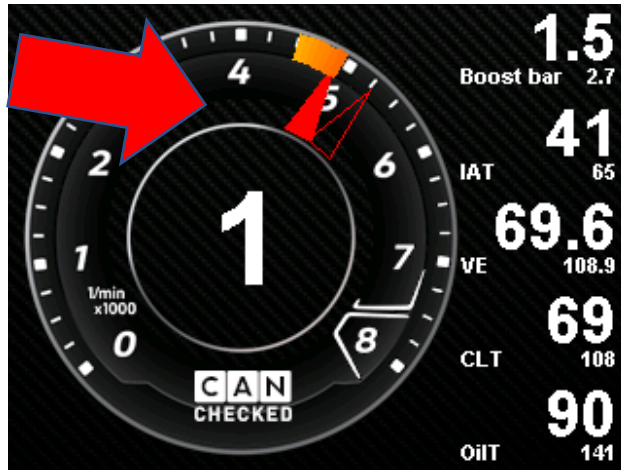

Figure 63: needle widget on the TrackView

Interesting with the *needle* widget is the drag pointer (shown on the picture as a transparent pointer) with which you can see the peak of the last milliseconds (function can be deactivated in the *DSS*).

Please put the matching speedometer disc as a *picture*. With *x/y coord* you can adjust the position of the widget as usual. With *radius1* and *radius2* you can adjust the size of the needle. This is stretched between *radius1* and *radius2*. The width determines the width of the needle. As with the other *widgets*, the *needle* must also be assigned a *sensor* and the color of the pointer is done as usual via the color wheel.

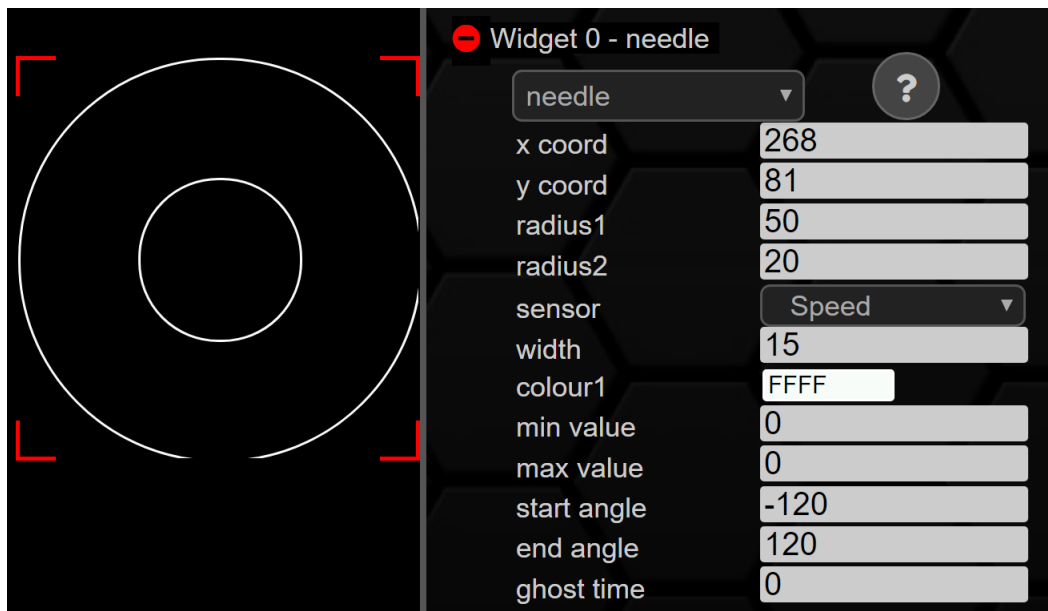

Figure 64: Configuration needle

The menu items *min value* and *max value* are the lower and upper limits of the *widget*. If there are zeros here, the values for min. and max. of the *needle* are taken from the *TRI/TRX file*.

The menu items *start angle* and *end angle* refer to *min value* and *max value* and are, as already specified in the *round meter* in degrees, where 0 degrees is at 12 o'clock. For example, if you want a classic "6 o'clock speedometer" your *min value* is 0 and the *start angle* is -180.

As already known from the *round meter*, there is also a split-seconds pointer in the *needle widget*. This is configured via the menu item *ghost time*.

### 9.3.2.17 Overlay

With the *overlay* widget you can display flashing warnings regardless of the min and maximum warning values stored in the *TRI/TRX file*. You can freely configure the flashing frequency and color. The *overlay* widget can be found by default for various purposes (warning, shiftlight) on the following pages:

- *DailyDash*
- *TrackView*
- *AirflowLogging*

In the following figure, the *overlay* widget is used as a shiftlight. In this case, it is fixed to the *sensor* speed and starts flashing at a frequency of 60 Hz as soon as the warning threshold (6000 rpm) is exceeded.

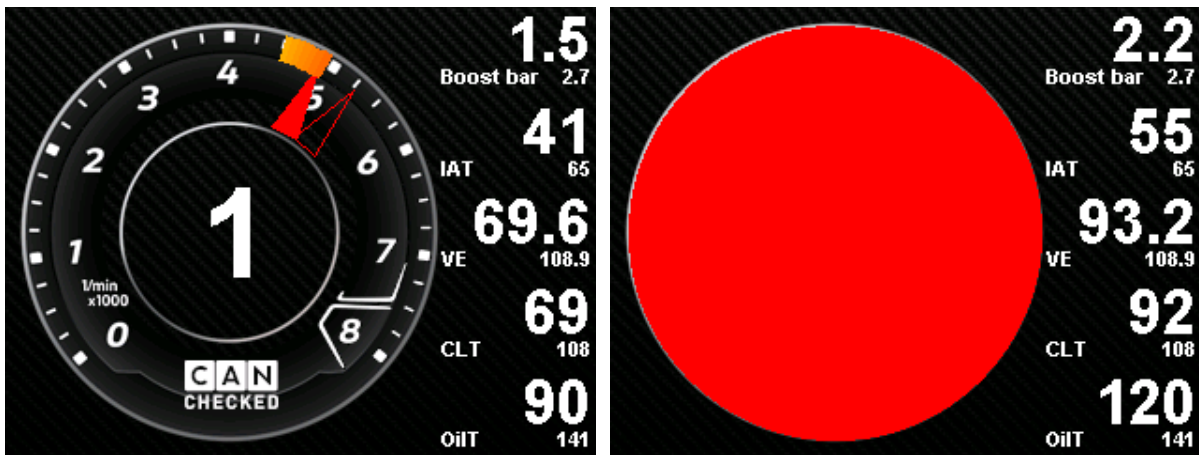

Figure 65: overlay widget in both states on the TrackView

Depending on which *sensor* you assign to the *widget*, it can be used as a switching flash, as a warning or as a confirmation. Like the other *widgets* before, you can change it in size (x/y size) and position (x/y coord). In addition, you can choose between the round or the square shape (*rectangle*, *circle*). Also adjustable is the frequency (*time ms (x10)*) and the color (*colour*) with which the widget should flash. The point *value* describes the activation limit. If the current value of the *sensor* is greater than the value in *value*, the *widget* becomes active and flashes.

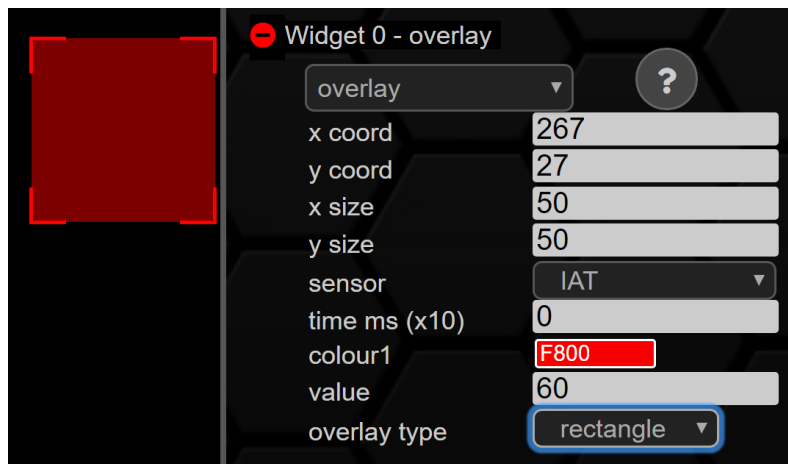

Figure 66: Configuration overlay

### 9.3.2.18 Pixel

The *pixel* widget is interesting for all users who use the *log* function. Those *sensors* created as a *pixel* widget are additionally queried and stored in the log file.

If you have now created an appealing page on which, for example, you monitor the boost pressure and the exhaust gas temperature and want to log along, but you would also like to see lambda and speed in the log without displaying these *sensors* as *widgets* (*round meter*, *sensor value*, etc.) on your new page, you can create the *pixel widget* twice. Once for the sensor lambda and once for the *sensor* speed. Now these two sensors are additionally queried and logged in addition to the *sensors/widgets* created on the page.

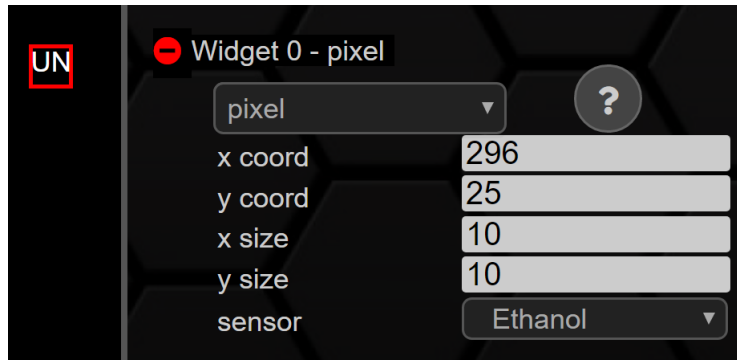

Figure 67: Configuration pixel

Of course, this *widget* can also be adjusted in size (x/y size) and position (x/y coord), but this does not play a major role because it is not visible on the display itself and only works in the background during logging or warnings. This makes it more important to assign the desired sensor in the log.

### 9.3.2.19 performance meter

You can use the *form meter* to test improvements to your vehicle **on closed test tracks**. The *form meter* is active and measures as soon as you are on this page. The following (best) times are stored:

- 0-100
- 0-200
- 100-200

**ATTENTION:** The speed is determined by the rolling circumference of the tires of your vehicle and is very accurate not **GPS-based**. A correction due to slope / gradient and tailwind or headwind does not take place.

A representation of the *form meter* can be found in the figure below.

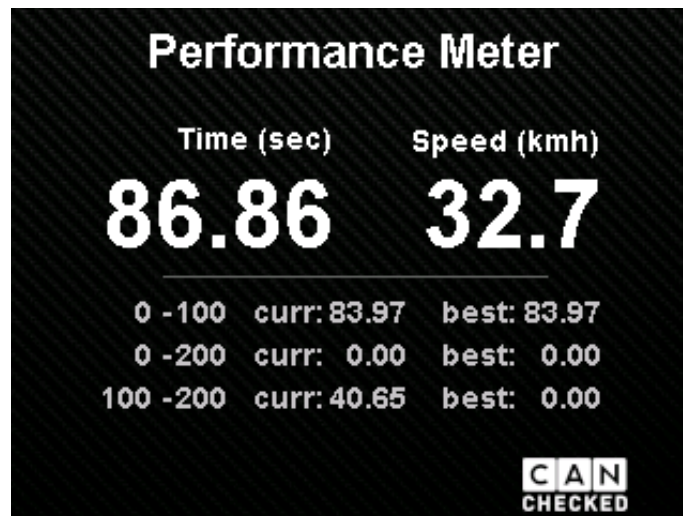

Figure 68: Display view of the performance meter

Like the other *widgets*, the *performance meter* is also customizable in size (x/y size) and position (x/y coord). However, the size should not fall below a minimum size of 240x120 to ensure proper representation.

Analogous to the other *widgets*, the corresponding *sensor* (in this case Speed) must also be assigned here, and the units must be defined.

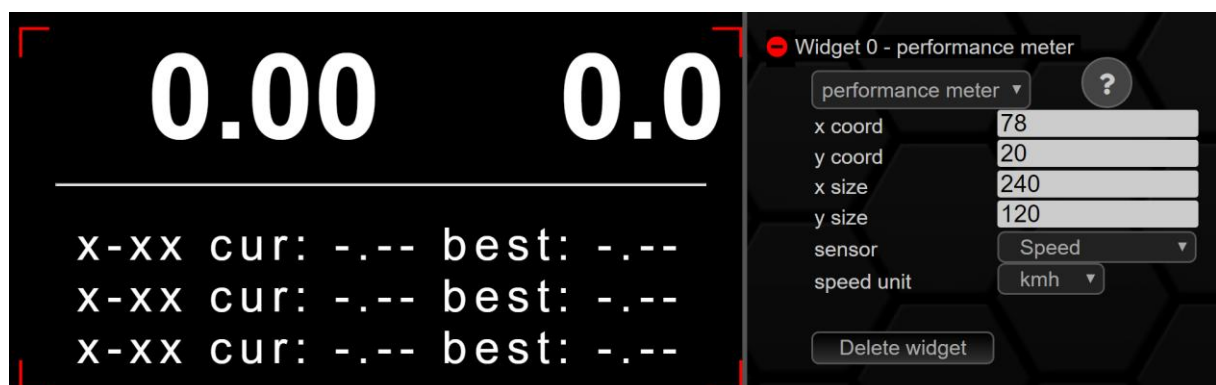

Figure 69: Configuration performance meter

### 9.3.2.20 status rectangle

The *status rectangle* widget can be used similar to the *icon widget*. It is also variable in position (*x/y coord*) and size (*x/y size*). Each of the two states can be assigned a color or a gradient using the color wheel. In the example below, the *widget* is used to map the state of cruise control. If a 10 (*status value*) is received on the bus, the status is activated, and the *status rectangle* changes its color from red to green.

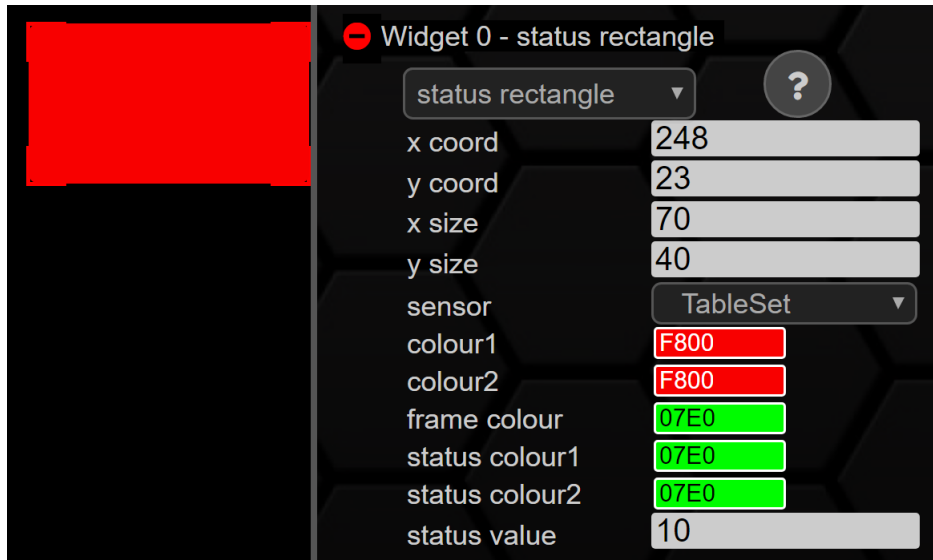

Figure 70: Configuration status rectangle

### 9.3.2.21 rectangle

The rectangle, like the *status rectangle*, is adjustable in size, position and color (gradient). It is not assignable to any *sensor*, so you can use it as a construction element for your pages. Due to the variable size and position, this widget allows you to draw fine lines to spatially separate your ads. You can also use it to create backgrounds for other ads. In the figure below, the *rectangle* was used to sketch the maximum deflection of the *vertical bar* above.

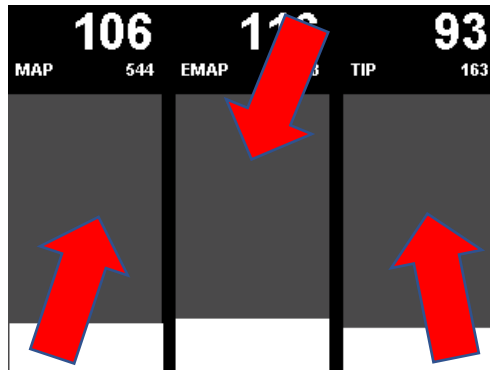

Figure 71: rectangle as background for the vertical bar

You can adjust this *widget* in position (*x/y coord*) and size (*x/y size*). Furthermore, you can use the color wheel to color the *rectangle*, provide it with a gradient and determine the color of the frame color.

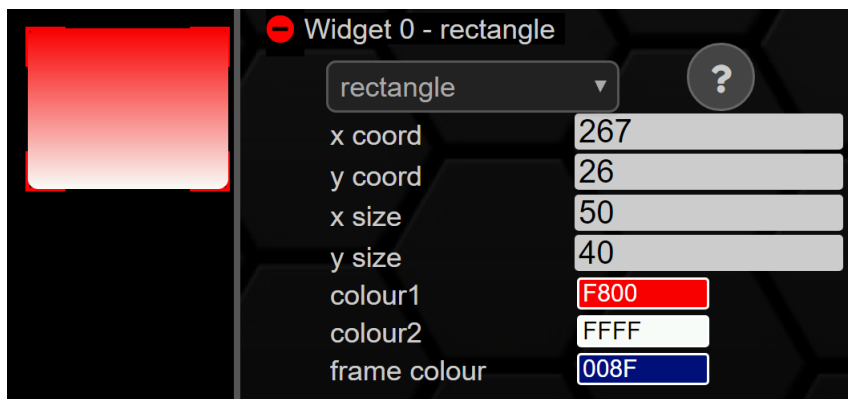

Figure 72: Configuration rectangle

### 9.3.2.22 text field

With the *text field* widget, you can design your pages even better and create your own words or sensor names on your pages. The text fields can be changed in position and size and the size and color of the font is variable. **No special characters** may be used.

The text field can be configured as usual in position (*x/y coord*) and size (*x/y size*). **A maximum of 32 characters** is allowed per text field. Several text fields can be created per page.

In the example below, the background of the widget has been colored blue with the color wheel (*bg colour*) and the color of the font (*font colour*) has been changed. As with the other widgets, the **background** of *text field* becomes transparent if **bg** and **font** have **the same color**. Font size can be used to adjust the size of the font. By default, the font is left-aligned within the field, if the corresponding hooks are set, it can also be centered or right-aligned.

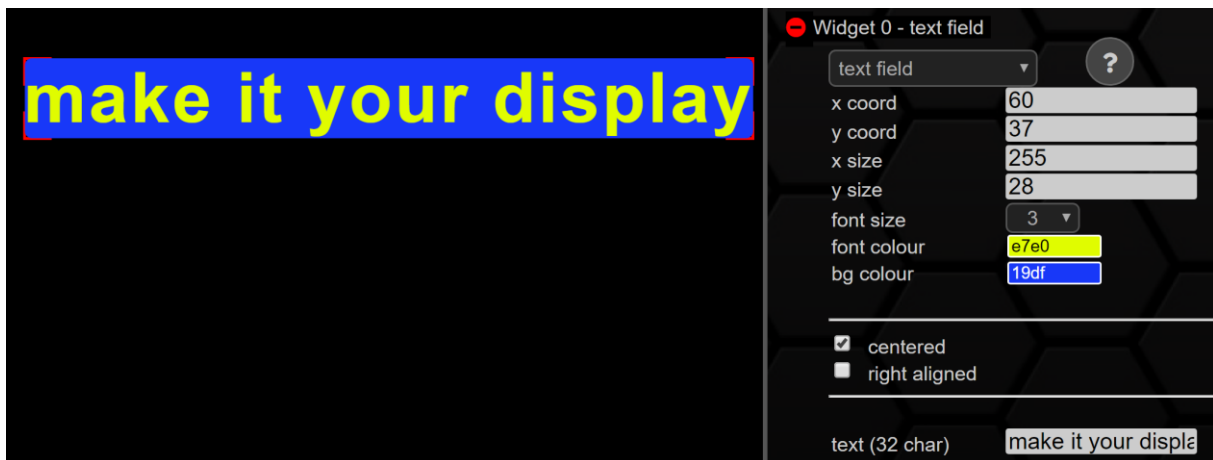

Figure 73: Configuration text field

### 9.3.2.23 picture

In addition to the text fields, you can also use the *picture* widget to make your *pages* more appealing or provide a custom background. In the figure below, the CANchecked logo and the carbon background are created as a *picture* widget.

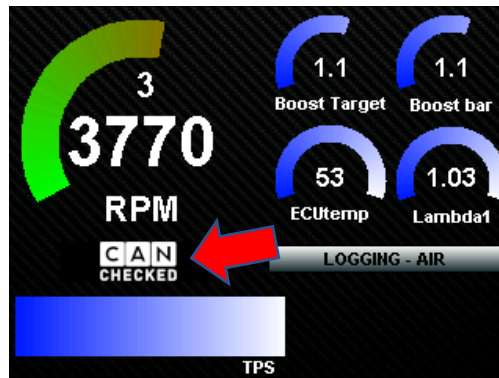

Figure 74: Carbon background and CANchecked logo as picture widget

The position of the image can be defined as usual with *x/y coord*. The points *x/y* size do not determine the size of the image, but only the image section in the preview. The size of the image is determined by the size when uploaded. The screen measures 320x240 pixels. The recommended size for icons is 30x30 pixels, for smaller logos 100x40 pixels is recommended. If the desired image has been scaled appropriately and uploaded via the *upload* section and then be selected from the drop-down list in the *picture* widget.

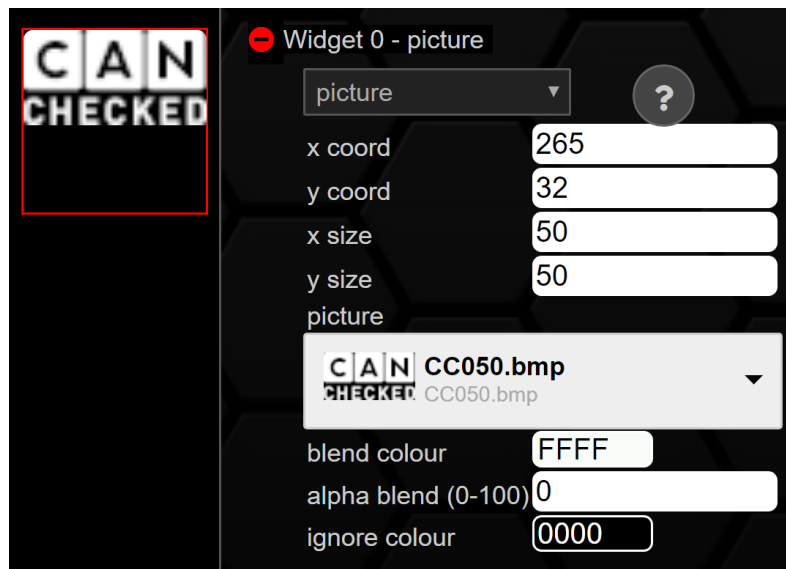

Figure 75: Configuration picture

The *blend* colour function can be used to specify the colour with which the image should be mixed. The strength of the mixture is configured via *alpha blend*, where the value 0 does not correspond to any mixture. With *ignore colour* you can determine which color becomes transparent within the image. This function can be used to crop logos.

### 9.3.2.24 RPM bar

The speed bar is already known from the Gen1. Of course, you can also assign other *sensors* to it. An illustration of the speed bar is visible below. Here, the *sensor* speed is assigned to the widget.

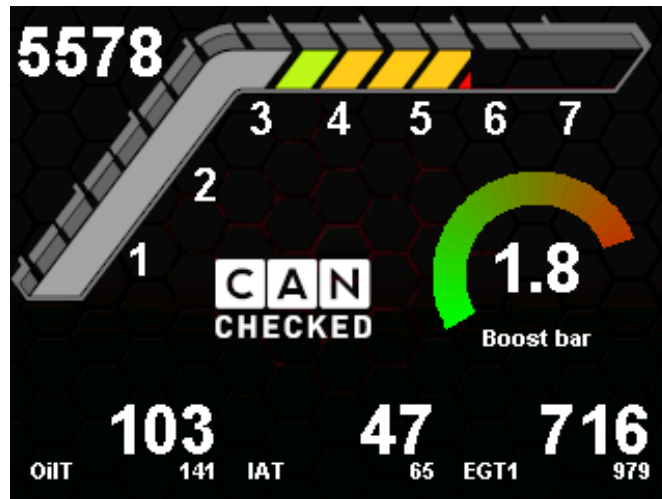

Figure 76: RPM bar as predefined page

For example, an oil pressure indicator in digifiz style would also be conceivable. As with our other widgets, there are no limits to your creativity, and you can make the CANchecked data display your data display.

You can calibrate the *RPM bar* in position (*x/y coord*) and size (*x/y size*). In principle, this *widget* does nothing more than gradually fade in and out an image depending on a *sensor*. As with the *picture widget*, the colours of the image can be mixed or cropped using *blend colour*, *alpha blend* and *ignore colour*.

*min* value defines the lower threshold value for starting an overlay, and *max* value defines the value at which the image is fully displayed. Furthermore, the direction of the overlay can be defined:

- from left to right
- from right to left
- from bottom to top
- from top to bottom

Various predefined speed bars are possible. Due to the new design, however, specially designed speed bars can also be uploaded and used. For uploading and scaling, see Chapter 9.6

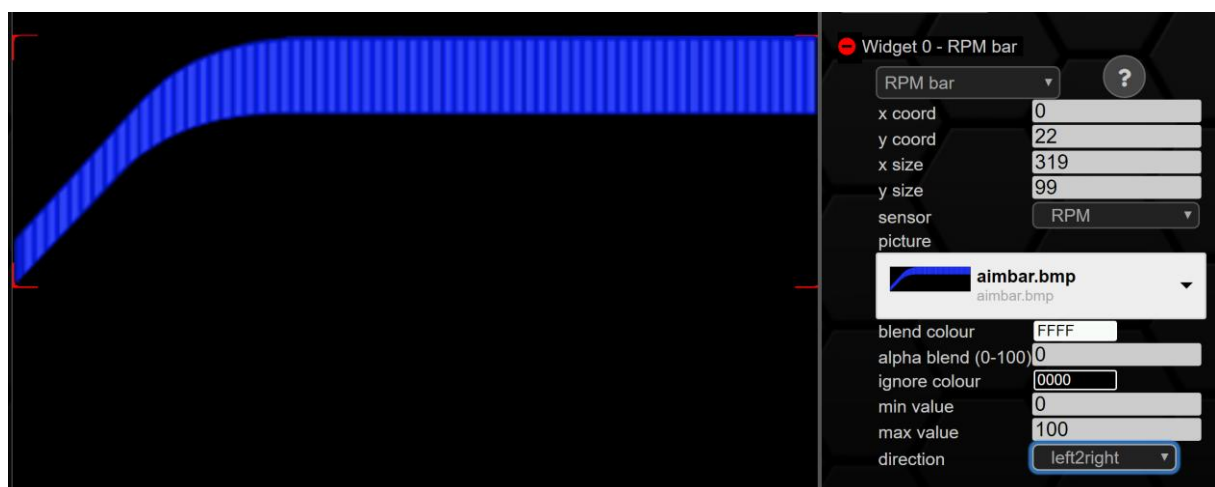

Figure 77: Configuration RPM bar

In contrast to the *RPM bar* of the Gen1 displays, other *sensors* can also be assigned to this *widget* with the Gen2. For example, it is possible to show or hide images/logos based on the accelerator pedal position.

Attention: you can only use **one** image for RPM Bar per page – i.e., several RPM Bar widgets with the same image.

## 9.4 Log Viewer

In the *Log Viewer*, the 4 To view a *log*, you have to navigate to the *Log Viewer* tab and import the *logs* stored on the data display into the *DSS* via *import from Display*. In this navigation bar you can also export *logs* to your PC or load them from your PC into the *Log Viewer*.

To open a *log*, click on it and open the *log* via the *load* button.

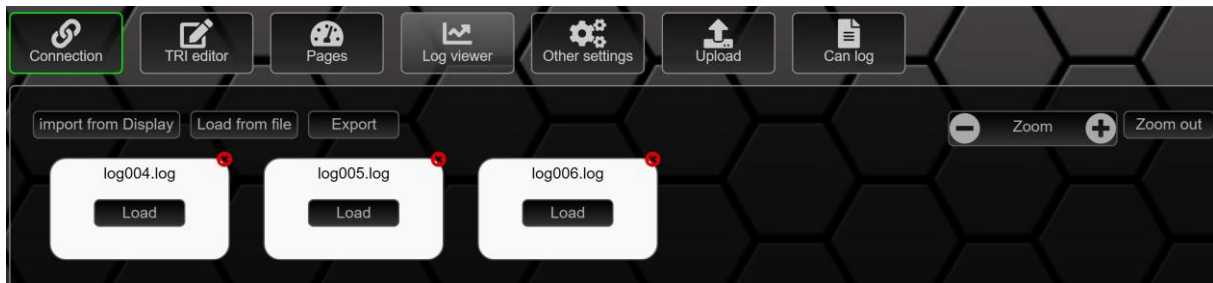

Figure 78: Overview Log Viewer

Once you have opened a *log*, the diagram will be displayed on the left half of your screen and the available sensors on the right half. Now you can select the *sensors* relevant to you from this list by clicking on them and display them in the diagram. With the mouse cursor you can stretch the relevant areas by clicking and pressing and zoom in and out via the zoom function in the upper right corner of the *log*.

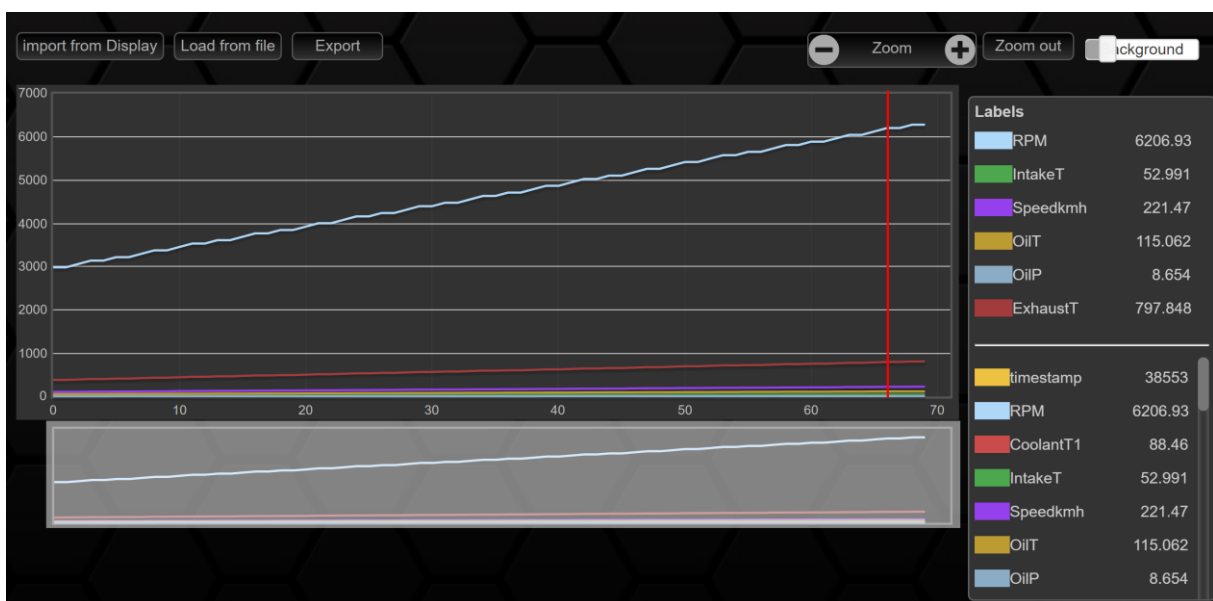

Figure 79: opened log

To delete a *log*, please click on the red cross and confirm the deletion with ok.

## 9.5 Other settings

As with the *setup* on the data display itself, changes can also be made to the settings of the data display in the *DSS*. If changes are made here, they must always be transferred to the data display with the *write to display* button at the bottom left.

### 9.5.1 General settings

Under *General settings*, the dwell time of the start screen can be set by menu item *Start screen*. Here a duration of 0-5 seconds is adjustable.

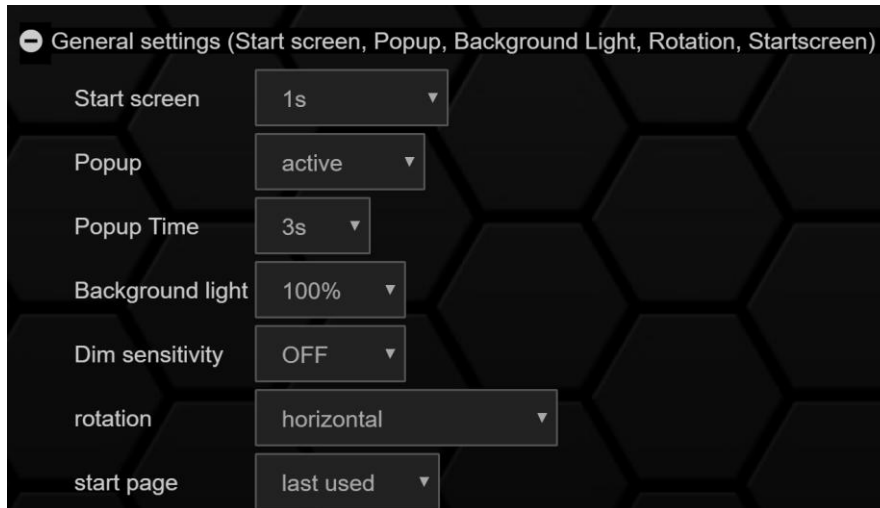

Figure 80: General settings

Furthermore, the popups and the dwell time of the popups can be defined under *Popup* and *Popup Time*. Further menu items are backlight (*Backgrounds light*), the sensitivity of the dimming (*Dim sensitivity*), the orientation of the display.

### 9.5.2 Can Bus

As in the menu on the data display itself, you can de-/activate the can scheduling in this submenu in the *DSS*, set the can speed, de-/activate the OBD2 29-bit extension and set a timeout for the next data query (timeout).

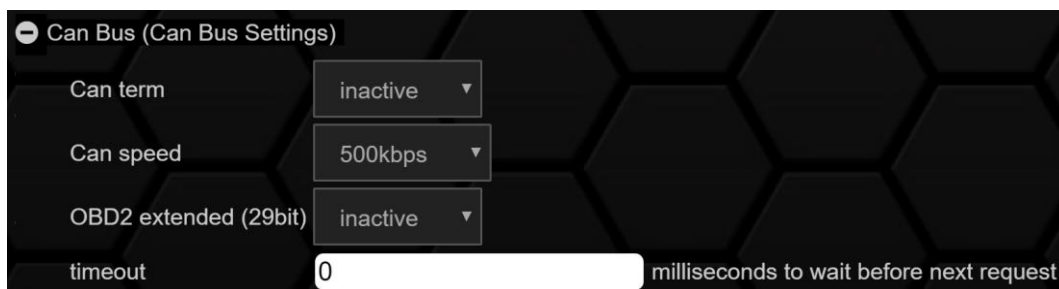

Figure 81: Can Bus

### 9.5.3 Shift light

This is analogous to the configuration of the shift light menu on the data display. You can adjust the speeds and colors of the shift light to the corresponding speeds. Under the menu item *brightness* you can set the *brightness* and under *direction* the direction of the shiftlight.

### 9.5.4 Gears

In the submenu *Gears* you can also specify the gear ratio for gear calculation.

### 9.5.5 Sensor init

Analogous to the setup on your data display, the *sensor init* settings can also be made directly via the *DSS*.

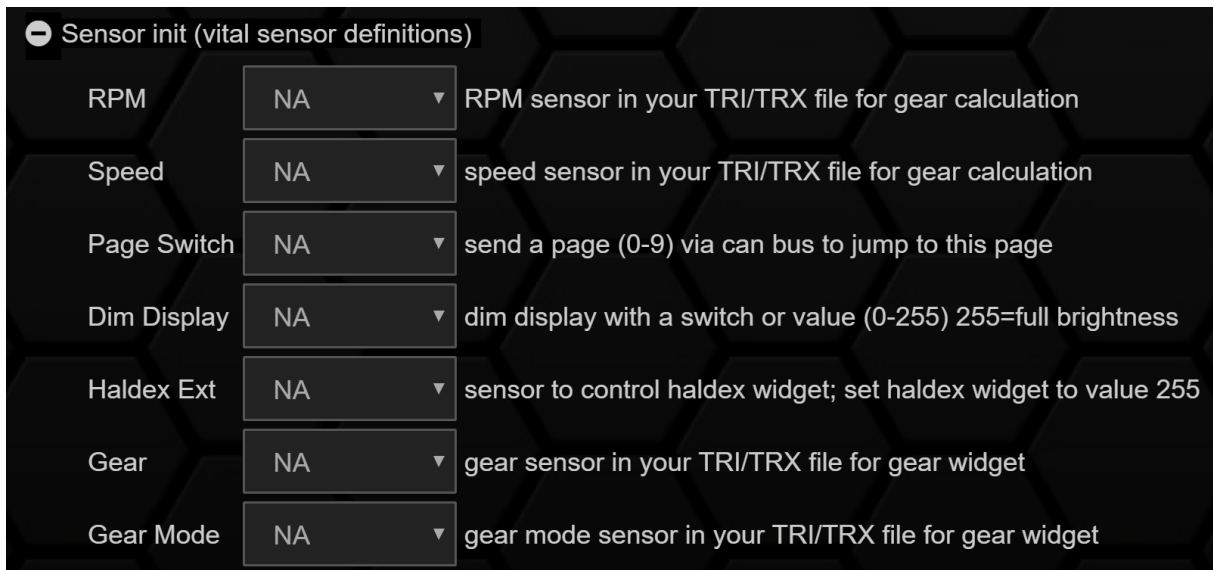

Figure 82: Sensor init

For most applications, it is sufficient to set *RPM* to the sensor speed, *speed* to the *sensor* speed and *gear* to the sensor gear. For automatic vehicles, *Gear Mode* can still be set to gear. The others are to be set to NA. The explanation of the functions can be found in the figure above.

Since firmware version 4.100i43, the 'Odometer' option has been available here. The odometer is the mileage counter on your display. Prerequisite: The relevant functions for RPM and speed must be enabled.

Setting up the odometer is simple: Enter the current mileage in 'Sensor Init' and export it to the display. It will then continue to count up automatically. In the TRI Editor, you must now select the predefined "Odometer" sensor in Enhanced Mode via the "Add Sensor" button and add it to the TRI/TRX. You can now add a Sensor Value Widget to a page of your choice and assign the newly added sensor to it.

### 9.5.6 IO pins

This menu item cannot be accessed directly via the setup of the data display. In this menu item, the pins for the functions *PageSwitch*, *Brightness Frequency In*, *Output switch* and *Boost-PWM out* can be assigned and activated.

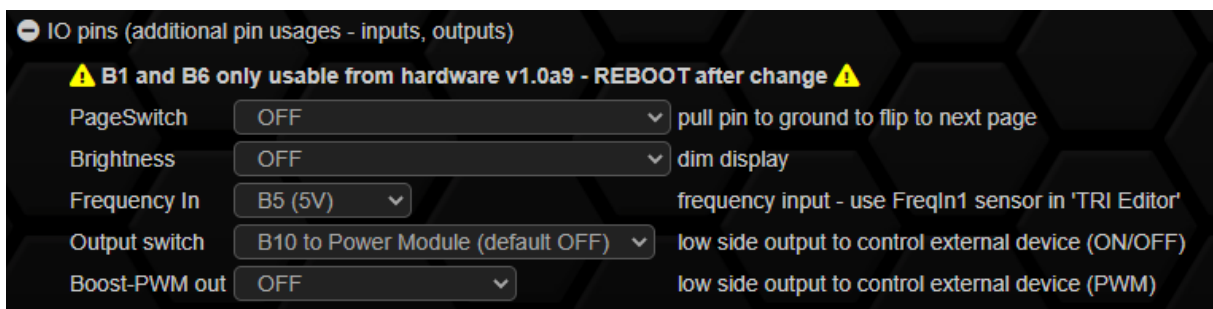

Figure 83: IO pins

*PageSwitch* can be used to switch from one side of the data display to the next by grounding one of the pins selectable in the drop-down menu. If you want to switch the page to 5V, it is necessary to install an external pull-up resistor (10K Ohm) to 5V.

The same applies to the *brightness pin*, so the display can be dimmed by an external switch. It is possible to dim against ground or against a 12V signal. Please refer to the description in the *DSS*. If you set the dimming to B1, for example, you can dim against a 5-12V source. One application here would be, for example, the voltage of the instrument lighting for dimming the display.



In addition, the *background light* must also be set to determine how much the display should be dimmed. This can also be found in the *DSS* under *General settings*.

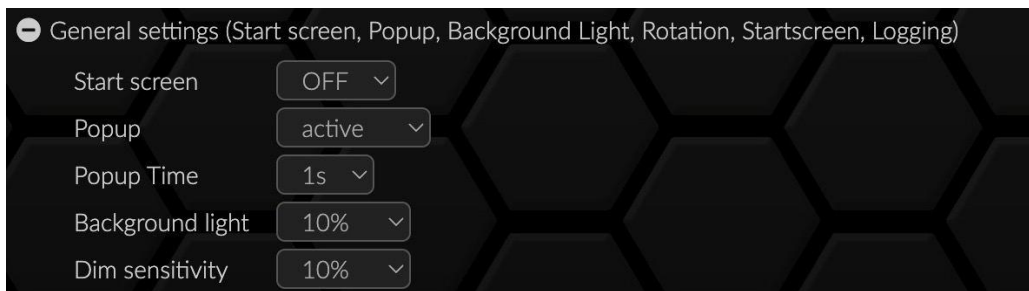

The *Frequency In* is used to feed 0-5 V square wave signals (e.g., wheel or charger speed, Ethanol) into your data display. For example, see our instructions for the FlexFuel Sensor (ethanol). By default, the pin for Frequency In is assigned to B10.

The output switch can also be configured here. Pin B7 (OFF) is preselected for this by default. On page 3 you will find the virtual button for switching the output switch with the current SD content. Of course, you can also link the output switch function to a user table in order to switch your output depending on input sensors at defined threshold values. Depending on the pin, you can **switch 0.5 to 3A** ground. You can find an application example in the FAQ in chapter 11.21.

The boost PWM out function can be assigned to one of three available pins and requires a licence. More on this in chapter 9.5.10.

### 9.5.7 Can Transmit

In this menu item you can configure the start state (*Default status*), the behavior (*Momentary* = button, otherwise switch) as well as a pop-up window (*Inform*) for your can switches.

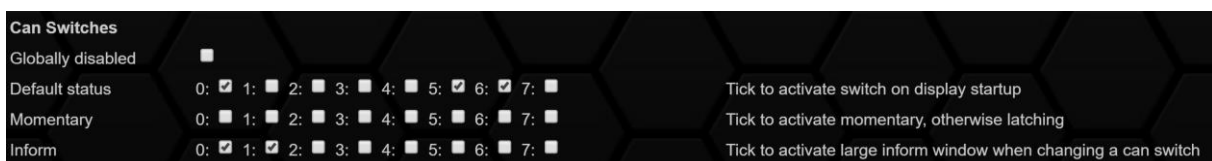

Figure 84: Can Switches

Furthermore, you can send up to four Custom Can Frames from your data display to the Can bus. The frames can be activated individually (*Activate*).

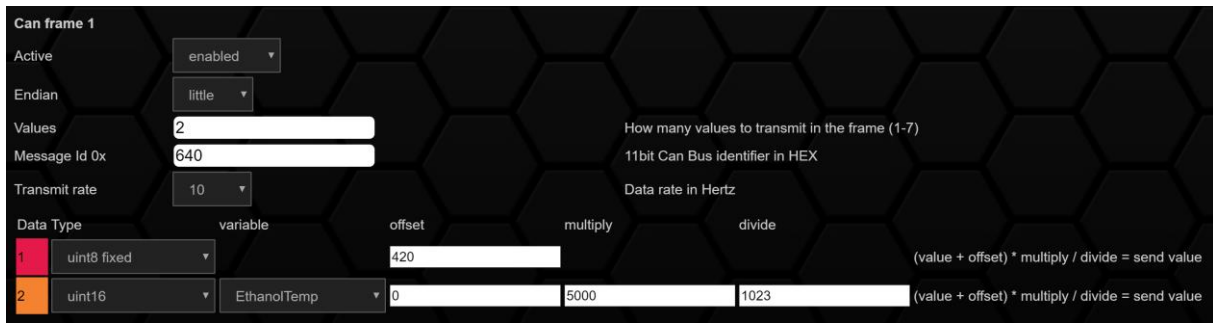

Figure 85: Can frame

To do this, the number of messages in the frame, the Base ID (*Message Id 0x*), the transmission rate (*Transmit rate*) as well as the Endianness (*Endian*) and the data type (*Data Type*) must be specified. The frame can then be filled with *sensors*, *switches* or fixed values. By clicking on *write to display*, the changes are reflected in the display.

Any settings you make here are at your own risk. So be very careful with the messages that are sent here.

#### 9.5.8 User tables

The *User Table* can be used to combine two *sensors* into a common output. In the example below, a value between 0 and 100 is generated from the speed and accelerator pedal sensors, depending on the condition. This value can be used, for example, to control the actuation of a boost pressure control valve (N75).

Another conceivable application would be the control of a water-methanol injection (WMI) via the sensors IAT (intake air temperature) and boost (boost pressure).

Of course, only a 1D table can be created to store a characteristic curve. Regardless of whether it is a 1D or 2D table, the values on the axes must be arranged in ascending order. For this purpose, it may be necessary to transpose or invert some characteristic curves.

Via the *DSS*, the resolution can be set in 1 to 0.001 steps. The size of the *User Table* is set via the + and buttons next to the table. The sensors are assigned by clicking on the axis label (all *sensors* available in the *TRI/TRX file* can be selected).

Values can be entered by clicking on individual cells. In addition to the manual entry via the keyboard, the mathematical functions can also be added and subtracted as well as interpolated if several cells are selected.

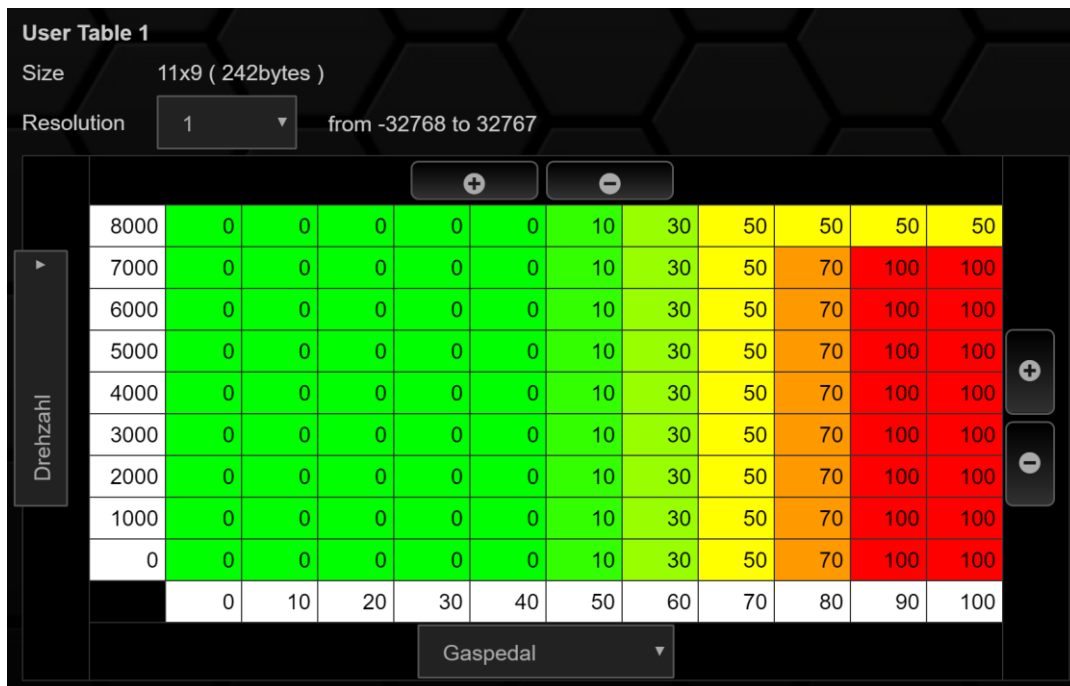

Figure 86: User Table

By clicking on the *write to display* button, the newly created *user table* is transferred to your data display. In order to use the *User Table* as output, it must be created as an *internal sensor* in the *TRI editor*.

After each change in the table or the axis scalings, the display must be restarted for the changes to take effect.

### 9.5.9 Math Channels

With the *Math Channels*, you can link *sensors* together through logical functions. You can add, subtract, multiply, and divide from the basic arithmetic operations with up to five variables (*sensors*) or fixed values. Choose a total of up to eight *math channels*.

In the following example, the *power* in kW is calculated from the torque and speed sensors. The mathematical formula for the calculation is:

$$P[W] = 2 * \pi * M[Nm] * n[1/s]$$

With the torque in Nm and the speed in 1/min and the result in kW, the following formula results:

$$power [kW] = \frac{2 * 3,14 * sensor\ torque [Nm] * sensor\ RPM [\frac{1}{min}]}{60 * 1000}$$

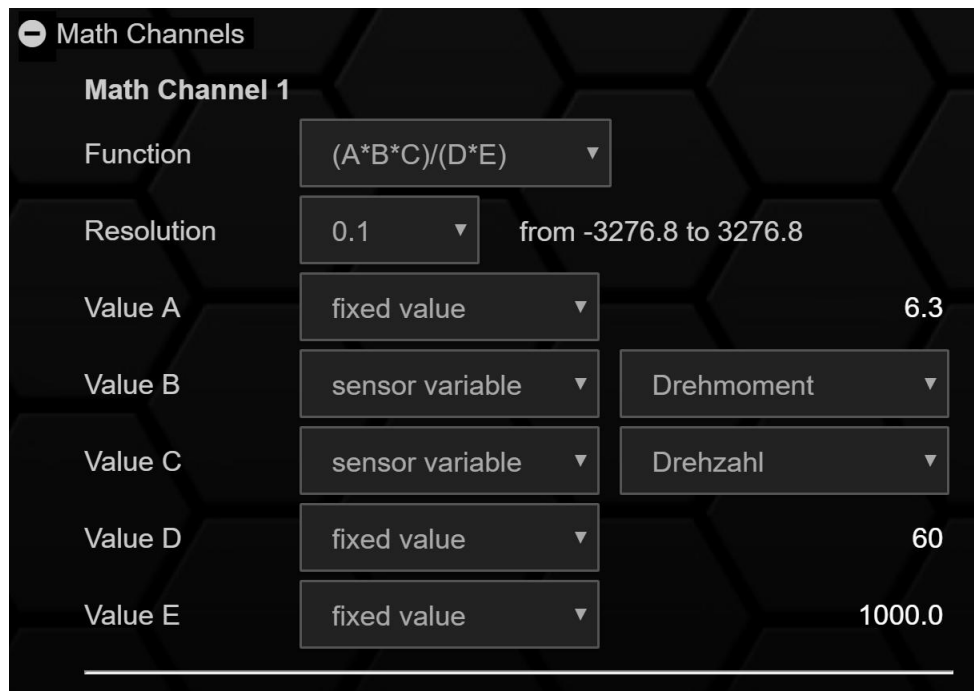

Figure 87: Math Channel

One decimal place is sufficient as a resolution here. Accordingly, a *resolution* of 0.1 is chosen. As in the *TRI Editor*, the **decimal separator is a period and not a comma!**

From the drop-down menu, select the most suitable calculation template, assign the variable and fixed values and click on the *write* to display button to transfer the newly created *Math Channel* to your data display. In order to use the *Math Channel* as output, it must be created as an *internal sensor* in the *TRI editor*.

#### 9.5.10 Boost/PWM Control

In this menu the **paid** item *Boost/PWM Control Addon* can be configured. Although this function can also be configured in DSS without purchasing a license, it only becomes active when the license key is entered on the data display.

The (PWM) output can be controlled via the previously created *User Table (Assign Usertable)*. The frequency (*Output Frequency*) and the PWM signal (*PMW output*) can be defined. Furthermore, the output can be inverted with the invert function. For boost control valves a frequency of 30 Hz is most common.

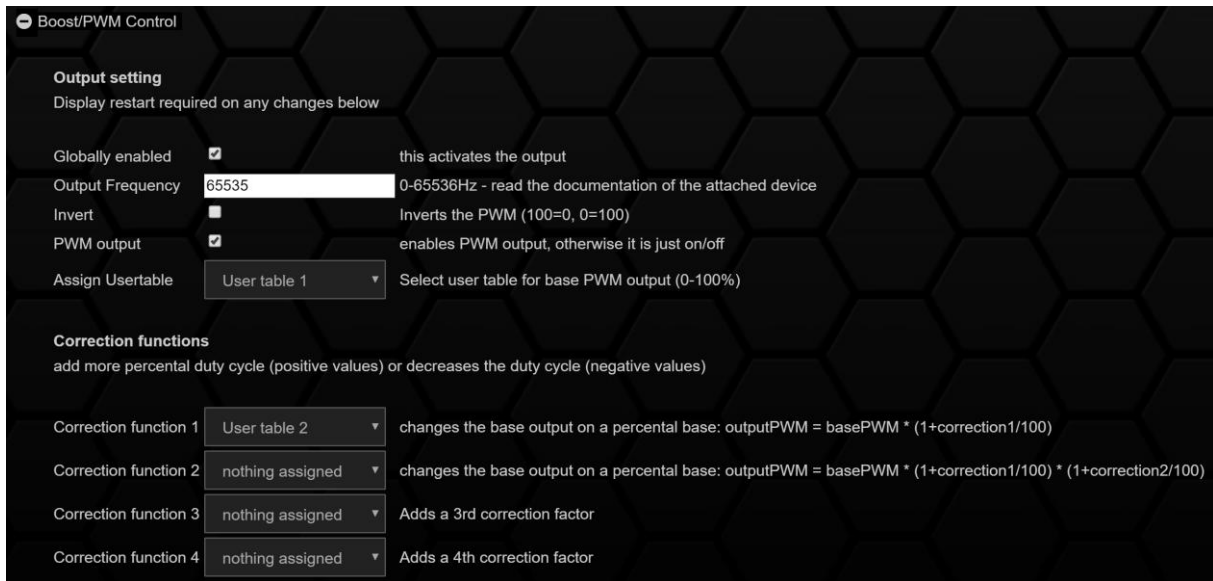

Figure 88: Boost/PWM Control

The output output can be corrected by further *user tables*. In the following example, the *boost output* is corrected (scaled) by a *table* with the gears. With this Boost by Gear, the boost pressure control valve is scaled down in the lower gears for more traction and scaled up even more in the upper gears.



Figure 89: User Table for boost correction

This function can also be used to map different power levels, provided that a potentiometer or switch is defined as axis scaling (*sensor*).

## 9.6 Upload

In the *upload* section of the *DSS* you have the possibility to transfer files to your data display. By clicking *Choose File*, you can search your computer for files and then upload them.

You can upload *TRI/TRX files* or upload logos and images that you want to add later to your pages via this button. The accepted data formats can be found below the button.

When uploading images and logos, it is very important to **scale** them to the appropriate size **before uploading**. For small icons we recommend a size of 30x30 pixels for logos a size of 100x40 pixels is recommended. The total screen size is 320x240 pixels. MS Paint can be used to scale the images and logos.

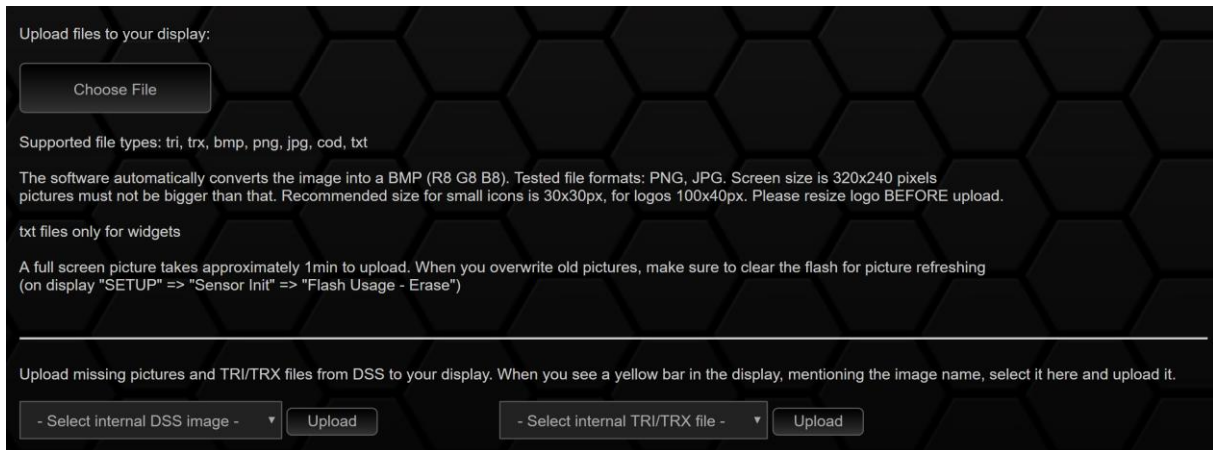

Figure 90: DSS Upload Section

If old images are overwritten, they must be deleted from the **flash memory** after successfully uploading the new image. To do this, please swipe down from top to bottom on the display after uploading, click on Setup -> *Sensor Init* -> *Erase flash*.5.3

In addition to uploading your own images and files, you can upload internal *DSS* images and *TRI/TRX files* via the lower area of the *upload* section. Please select this from the drop-down menu and start the upload to your data display via the upload button.

## 9.7 Can Log

The *Can Log* section of the *DSS* can be used to look for Can-IDs and frames or message packets and to sniff Can messages.

By clicking on *Start Log*, the received Can Bus data is displayed. The stop is done via the same button. *Clear Log* deletes the Can Log.

## 9.8 Work offline

The data display does not need to be permanently connected to the *DSS* to work with the *DSS*. For example, *TRI files* can be created offline, or page layouts can be configured.

However, there are the following points to consider:

- *TRI files* can also be loaded from the hard disk into the *TRI editor*, *TRX files* can only be loaded from the data display into the *DSS*
- In the *TRI editor* sensors must be loaded, otherwise only NA is displayed in the *Pages* section for all *sensors* and *widgets*
- The preview of the *widgets* in the *Pages* section is not 1:1 identical in terms of font size, and should therefore be done online on the display

For this reason, working without a connected data display is not recommended, but is possible in principle.

## 10 AIN Setup (analog inputs)

Your display has 4 analog inputs with 10bit resolution (0-1023).

Already successfully tested and installed sensors as well as their characteristic curves and connection diagrams can be found under [www.canchecked.de/downloads/](http://www.canchecked.de/downloads/). The analog inputs can display a maximum voltage of 5V, but can also tolerate voltages of up to 14 volts.

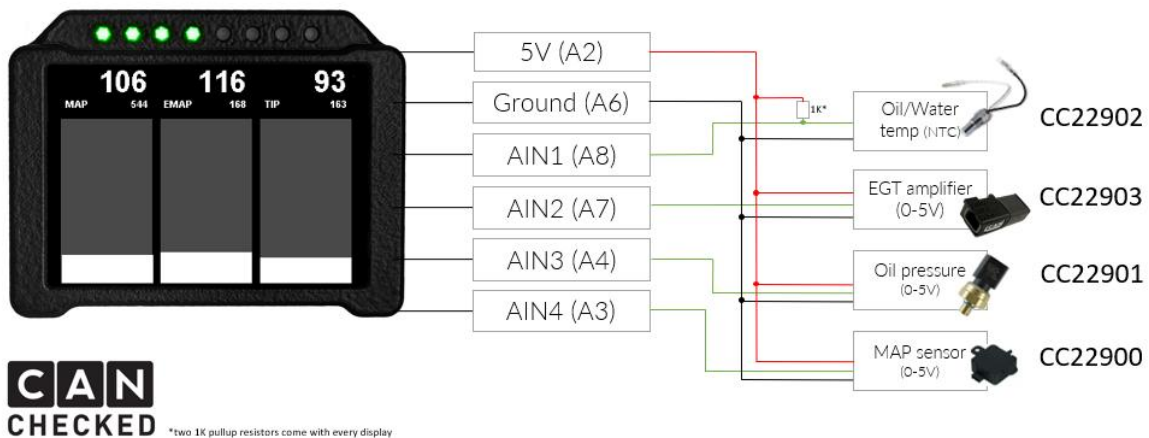

Figure 91: Connecting the AINs

The *analog inputs* are also set up via the *DSS*. If your *TRI/TRX* file does not yet have a sensor for an *analog input*, you can add it to your *TRI/TRX* file as described in chapter 9.2 via the *add sensor-internal* button by selecting the corresponding AIN(s), scrolling down and clicking on *Apply* button. Now you have to activate the *enhanced mode* in the upper right corner (see chapter 9.2.2) and can then configure the sensor by clicking on the corresponding AIN. You can change the name, adjust the attenuation, choose the type of mapper and of course activate the *analog input*.

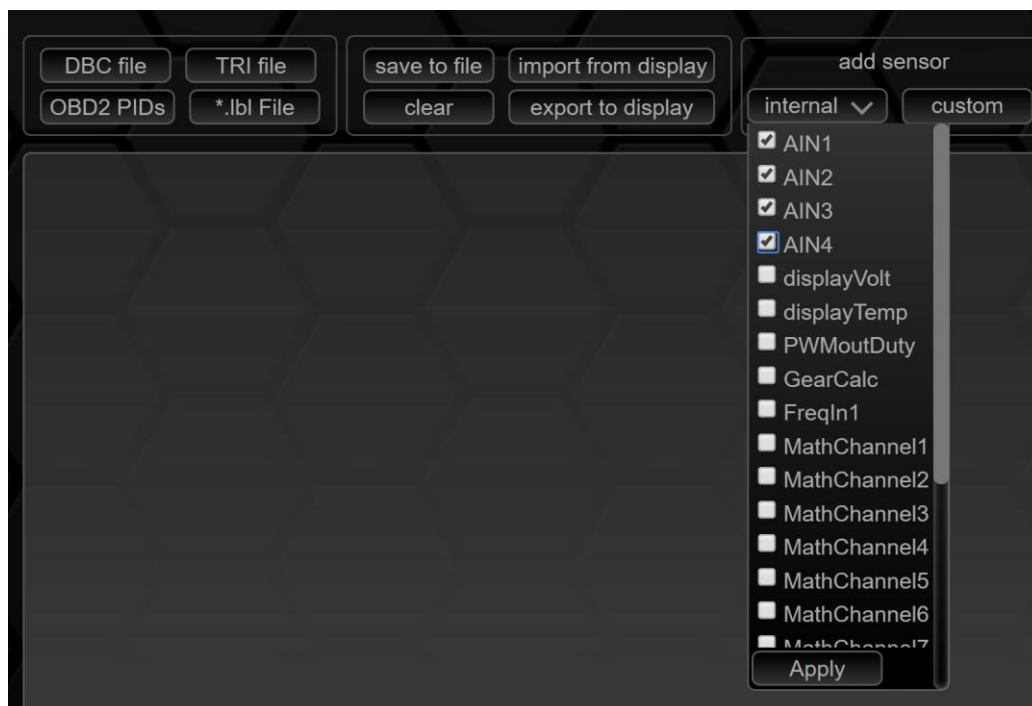

Figure 92: Adding AINs

The mapper can be set to three different options:

- *OFF* (shows the 10bit ADC value: 0-1023)
- *MAP*
- *NTC*

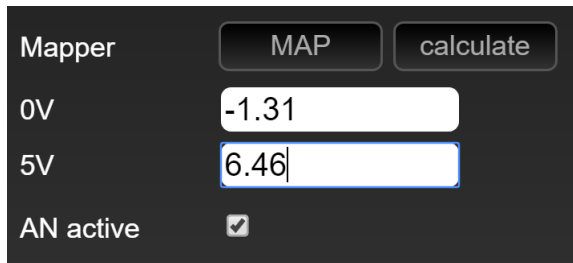

Figure 93: MAP

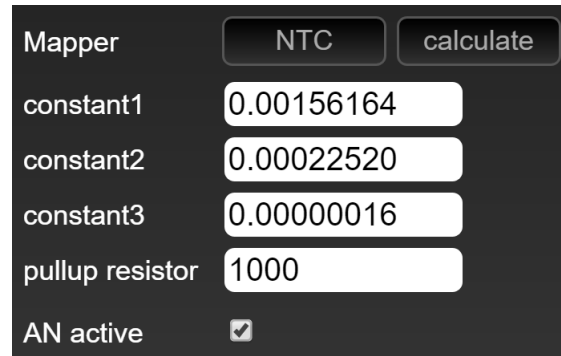

Figure 94: NTC

If set to *OFF*, no characteristic curve is activated and a value of 0-1023 is output.

If set to *MAP*, the values for zero and five volts can be entered. If the data sheet of your sensor only provides values for 0.5 and 4.5 volts, you can open the calculation tool by clicking on *calculate* to calculate the corresponding values for zero and five volts.

If set to *NTC*, you can enter the three constants of your NTC sensor as well as the pull-up resistance. If you only have three data points, the calculation tool will help you with one click on *calculate*.

While you're at it, you can directly assign the *min* and *max* values of your *sensor* 0

If the value of your *analog input* fidgets too much, you have the option of activating the attenuation. In the case of the *analog inputs*, this is hidden behind the point *Length*.



Figure 95: Attenuation of an analog input

If a 0 is entered here, the value is not damped. The maximum attenuation has a value of 249. A good starting value for damping is 210.

After you have adjusted all values, you can save your changes by clicking on *Apply* and then transfer them to your data display with the *export to display* button.

## 11 FAQ

This chapter collects recurring questions and offers solutions.

### 11.1 TRI/TRX file problem

If your data display shows you this error message, you have not selected a *TRI/TRX file*.

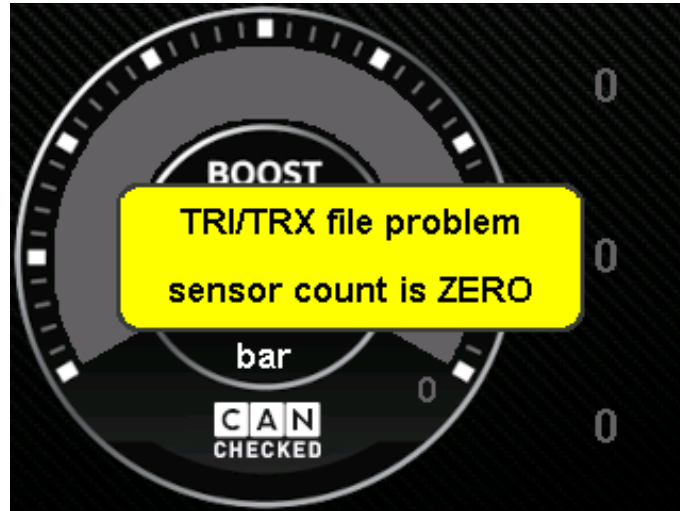

Figure 96: TRI/TRX file problem

Solution: Select *TRI/TRX File* as described in Chapter 6.3

### 11.2 Display does not turn on

If your display doesn't turn on, there's probably a problem with the power supply. In the first step, you can see if it starts when you connect it via USB. With the 5V from the USB your display should start, and you have to check your 12V wiring in the vehicle again.

If you look at the housing at the back of the display between the plugs, you will see a green LED light, which is activated by power supply (12V or 5V).

If the display does not start via USB, it must be sent in for further diagnosis by our service. Please contact [info@canchecked.de](mailto:info@canchecked.de) by email before submitting to describe your problem and discuss further steps.

### 11.3 Display remains black or white

If your display is suddenly only black or white and no longer starts as usual, please carry out a software update as described in chapter 8. You can find the latest firmware in the download area of our website. Please flash the file named "init\_gen2.1\_customer\_flash-erase.hex" first. Then you can follow the commands on your data display. Please select the appropriate firmware for your protocol (compare chapter 6.2). If your display remains black and white, you can try removing the SD card and starting up without it. You should now receive the error message "no SD." If this is the case, you can try another SD card with the appropriate SD content. If there is no improvement, please contact [info@canchecked.de](mailto:info@canchecked.de) with a complete description of the error.

### 11.4 I don't get any data (no can)

If your data display shows you under *Setup > Can Bus* in the upper right corner in red *no Can6.26* and *Can Low* on pin 14. With a continuity tester, the passage can be checked from the OBD connector to plug B and a fault at this point can be diagnosed or ruled out.

For vehicles where the data display is connected directly to the Can Bus, the Can termination (2x120 Ohm resistors, alternatively activation/deactivation of the ECU internal resistors) and the correct connection must be checked.

If no improvement occurs, please contact [info@canchecked.de](mailto:info@canchecked.de) with a complete description of the error.

### 11.5 Gear indicator does not work

The gear indicator calculates the gear from engine speed and speed. If your gear indicator does not work, this can have various causes:

- The *sensors* RPM, Speed and Gear are incorrectly assigned in the *sensor init5.3*
- Under Setup -> *Gears5.5*
- The *widget* itself is created incorrectly -> delete via *DSS9*

### 11.6 Yellow bar at the bottom of the data display

If images are missing on a page that are created in the layout of the page but are not stored in the flash memory, a yellow bar appears in the lower area and indicates the file is not found.

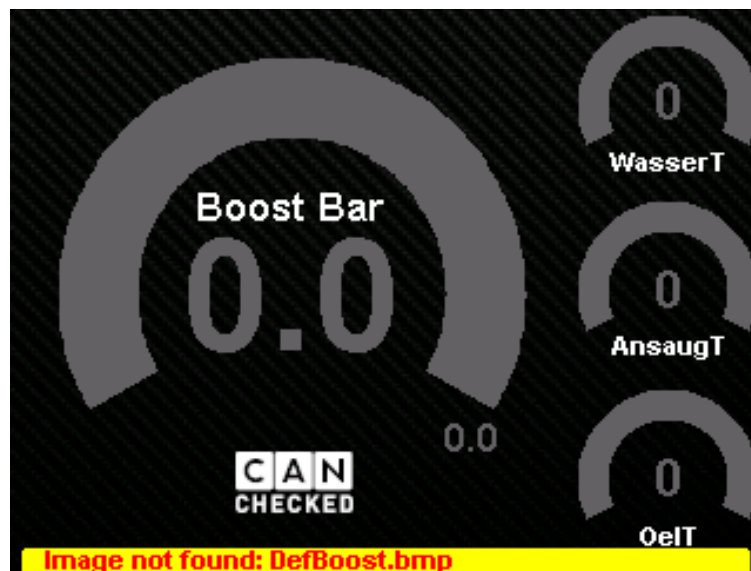

Figure 97: yellow bar

The error can be done by deleting the missing image from the page layout or by adding the missing image to the flash memory. The process for adding internal *DSS* images is described in Chapter 9.6

### 11.7 My Performance Meter runs permanently

If the *Performance Meter* runs continuously, even when stationary, the *widget* is assigned the wrong *sensor*. To assign the right *sensor* there are 2 ways:

unlocking the pages, click *performance meter*, assigning the *sensor speed*, locking the pages.

or

On the computer: Connect to the *DSS*, select the *performance meter*, assign the *sensor speed*.

### 11.8 My shift flash doesn't work

If the external switching flash does not work, there can be several reasons:

Please check whether plausible speed thresholds are stored for the individual LEDs under *Setup* -> *Shiftlight*.

Please check whether the *sensor RPM* is assigned appropriately under *Setup* -> 5.3

If both are correct, only the following remains to be checked: When starting the data display, the switching flash should run once. If this is not the case, the cabling must be checked.

### 11.9 How do I change my home logo?

It is possible to change the start animation or the start image. The animation consists of 20 images that are played one after the other. The files with the names *logo00.bmp* to *logo19.bmp* are located in the *pic* folder.

You have two options for changing, but no matter which one you choose, you have to convert your desired start animation/video into many small *.bmp* with a size of 320x240 pixels each or only provide one image with the appropriate size. If you upload only one image you only have one start image, if you upload several images, you have an animation in which the images run away one after the other:

- Manually remove the SD card, delete the 20 files and add the newly created images back to the folder
- From the *upload* section in the *DSS*, press *remove all logo\*.bmp files from SD* to delete all logos and upload the newly created images with the name *logo00.bmp* using the *choose file* button

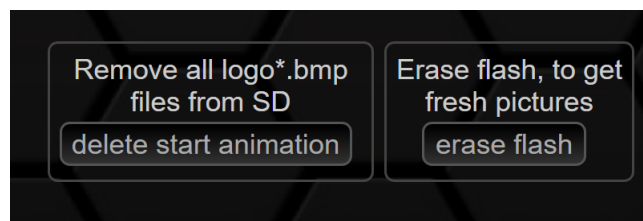

Figure 98: Buttons in the upload section

Once you have transferred all images to your data display, you must then press the erase flash button on the data display *under Setup* -> *Sensor Init* -> *erase flash* or in the upload section to delete the flash memory.

### 11.10 How to get other logos on the pages

Adding your own images and logos is done via the *upload* section in the *DSS* (chapter 9.6).

**Before uploading, the** images must be scaled to the appropriate size using a suitable program.

### 11.11 How do I rotate the UI of my display?

The user interface of your data display can be changed either on the display directly under Setup -> Pages -> Orientation or via the DSS (chapter 9.5.1).

### 11.12 My DSS gets stuck on page X

If your data display always gets stuck on a defined page when connecting, there may be two reasons for this.

Reason 1 on a Mac: The DSS was not moved to the application folder. Please copy the DSS to the application folder.

Reason 2: The page is damaged. The easiest way is to delete this page manually on the display and then create a new one.

To delete the page, please navigate to Setup -> Pages and enable and disable the page where it always hangs a few times. Then you will see the message **deleted** next to the page. Now the connection to the DSS should be done without any problems.

### 11.13 How can I find the cached images of the DSS

Windows: C:\Benutzer\[username]\AppData\Local\CANchecked-DSS\User Data\default\DSSdata

Mac: Macintosh HD>users>[username]>Library>Application Support>CANchecked-DSS>Default>DSSdata

### 11.14 How can I fine-tune a Can Bus sensor

The speedometer in your vehicle shows you a speed of 100 km/h, but on your display, it only shows 95 km/h. On the display we show you the true value and not an embellished value (the same applies to the coolant temperature). We show you the true value on the display and not an embellished value (the same applies to the coolant temperature).

If you want your display to show the same value as your speedometer, you can use the multiplier (see chapter 6). If you want your display to show 100 km/h instead of 95 km/h you must adjust the multiplier to 1.053 (100/95).

$$\frac{\textit{Value should}}{\textit{Value is}} = \textit{Multiplication factor}$$

The same applies to Can Bus sensors such as power or torque.

### 11.15 I can no longer edit the sensors on the display

Since firmware version 4.006, editing the sensors on the display is blocked by default. To unlock the pages, please unlock the corresponding page as described in chapter 5.10.

### 11.16 No connection with diagnostic tester possible

On some vehicles (especially BMW), no diagnostic connection is possible via the OBD socket when the display is active. To enable the OBD socket for diagnostics, the protocol must be deactivated or the OBD port must be unlocked. This process is described in chapter 5.2.5.

### 11.17 MicroSD card content and recovery

There are five or seven folders on the microSD card. If the card or the folders are empty, the display starts but does not show any data or available TRI/TRX files. The following figure shows the folder structure of the card.

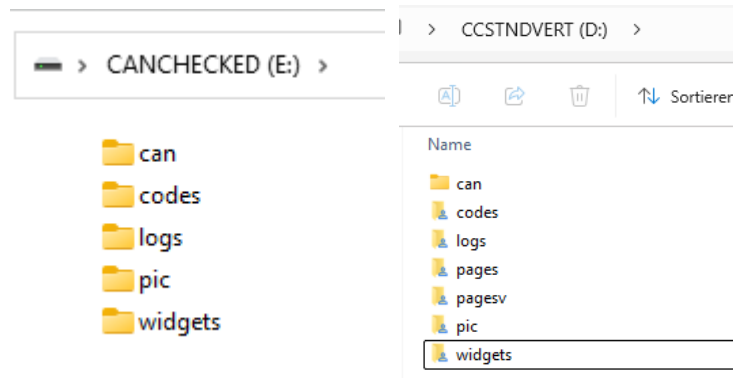

Figure 99: Folder structure of the microSD card

The TRI/TRX files are stored in the can folder. The .cod files required for reading out the error memory in plain text are stored in the codes folder. The logs folder contains the logging files stored with the display. The pictures and logos are stored in the pic folder. All arrangements of the pages are stored in the folder widgets. The pages and pagesv folders are for the preview pages feature and are therefore only available on new SD card contents.

If you receive a compressed ZIP archive from our website or by e-mail, it is imperative that this archive is extracted before the display is used again. The microSD card may only contain these five/seven folders; subfolders or superfolders are not permitted.

### 11.18 Resetting the display to factory settings

To reset the display to factory settings, 2 steps are necessary: Resetting the display electronics and resetting the SD card content.

The display electronics must be reset using 'init\_gen2.1\_customer.hex' and the CANchecked MFD2832 Updater as described in chapter 8.

The SD card content is reset via PC by formatting the SD card, then the new content must be restored as described in chapter 11.17.

SD card contents and the 'init\_gen2.1\_customer.hex' can be found at

<https://www.canchecked.de/downloads/downloads-mfd28-mfd32-mfd32s-mfa28-gen2/>.

### 11.19 MaxxECU with PQ34/PQ35 drivetrain

If the MaxxECU is operated with a PQ34 or PQ35 vehicle, can bus identifiers will overlap. To avoid this, please load the S-MAXX720.TRI file from our website and set the following in the MaxxECU under "Can Settings":

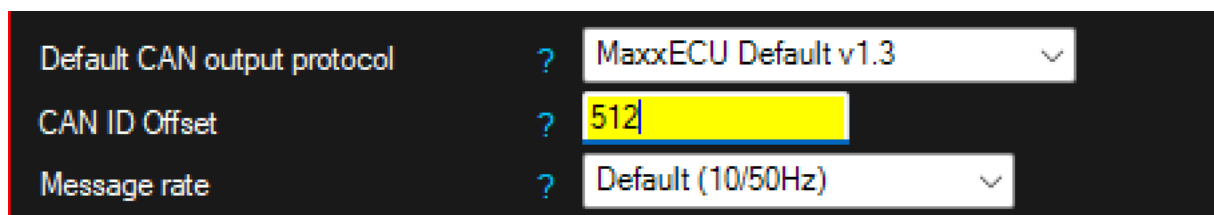

## 11.20 MaxxECU Can Switching

The 'Can Switch' option on the display must be set to MaxxECU:

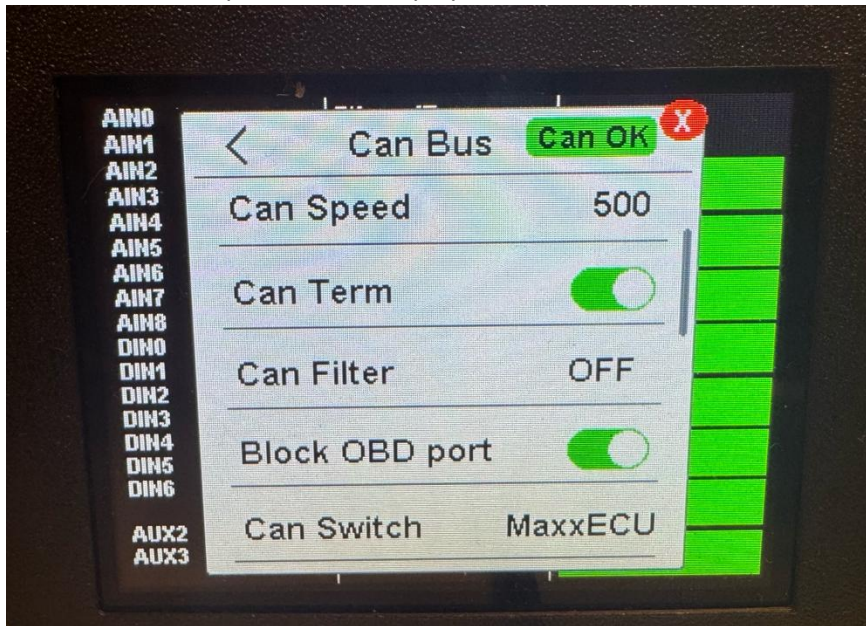

If other frames are required, individual transmission settings can be modified in the DSS under the menu item 'Other Settings->Can Transmit'.

By default, the stream is structured as follows, whereby all values are transmitted little endian (Intel) at 20 Hz. It is also possible to switch to other frequencies and big endian (Motorola).

Frame	Can Id in Hex	Byte1	Byte2	Byte3	Byte4	Byte5	Byte6	Byte7	Byte8
1	640	Can Switch1	Can Switch2	Can Switch3	Can Switch4	Can Switch5	Can Switch6	Can Switch7	Can Switch8
2	641	AIN1		AIN2		AIN3		AIN4	
3	642	MultiSwitch1		MultiSwitch2		MultiSwitch3		MultiSwitch4	
4	unused								

Can Switch 0 means OFF, Can Switch 1 means ON. The analogue inputs output a voltage of 0 to 5000mV. The MultiSwitches is be multiplied by 100 as the status, whereby this option can be set.

Settings in the MaxxECU Mtune:

Under Can Bus => CAN Tools => CAN Analyzer => incoming data only, please check that the data is shown on the display. To do this, please look for the IDs 0x640, 0x641 and 0x642.

You can then import the config completely and individually:

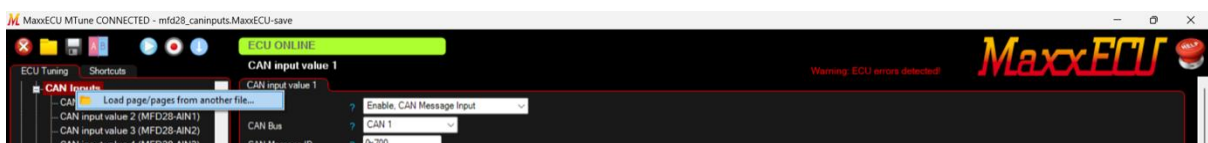

Of course, it is also possible to set it up yourself.

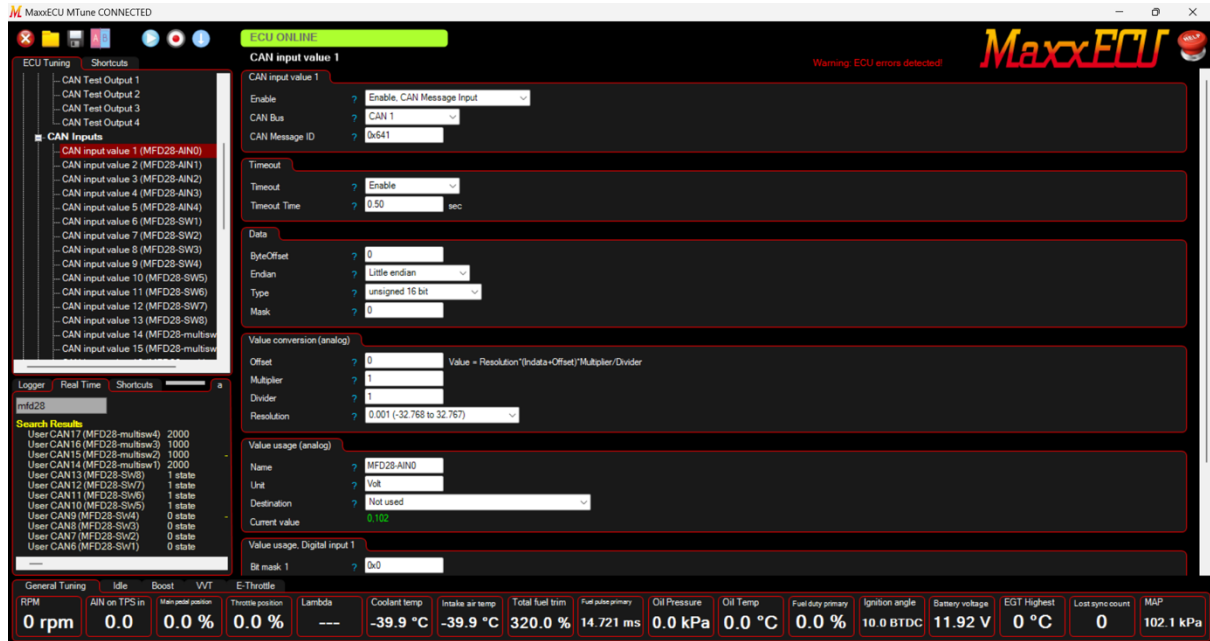

Only the 'byte offset' changes for the analogue sensors: AIN1=0, AIN2=2, AIN3=4, AIN4=6

Please set the multiplier, divider and resolution according to your requirements.

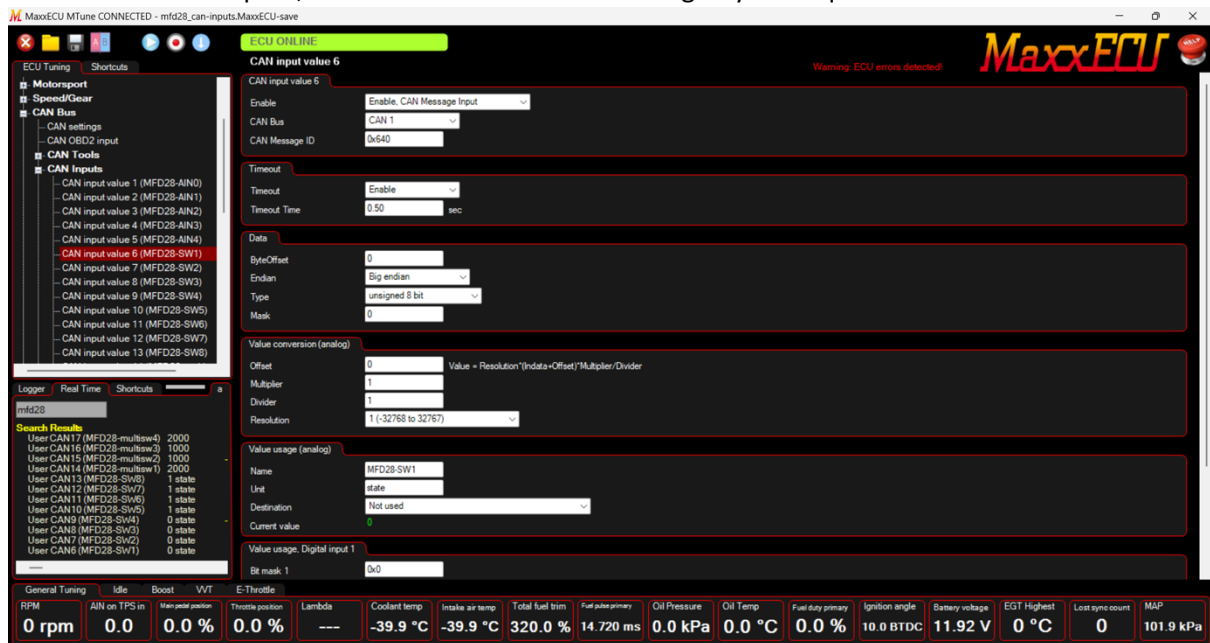

The 'byte offset' also changes for the switches: SW1=0, SW2=1, ..., SW8=7

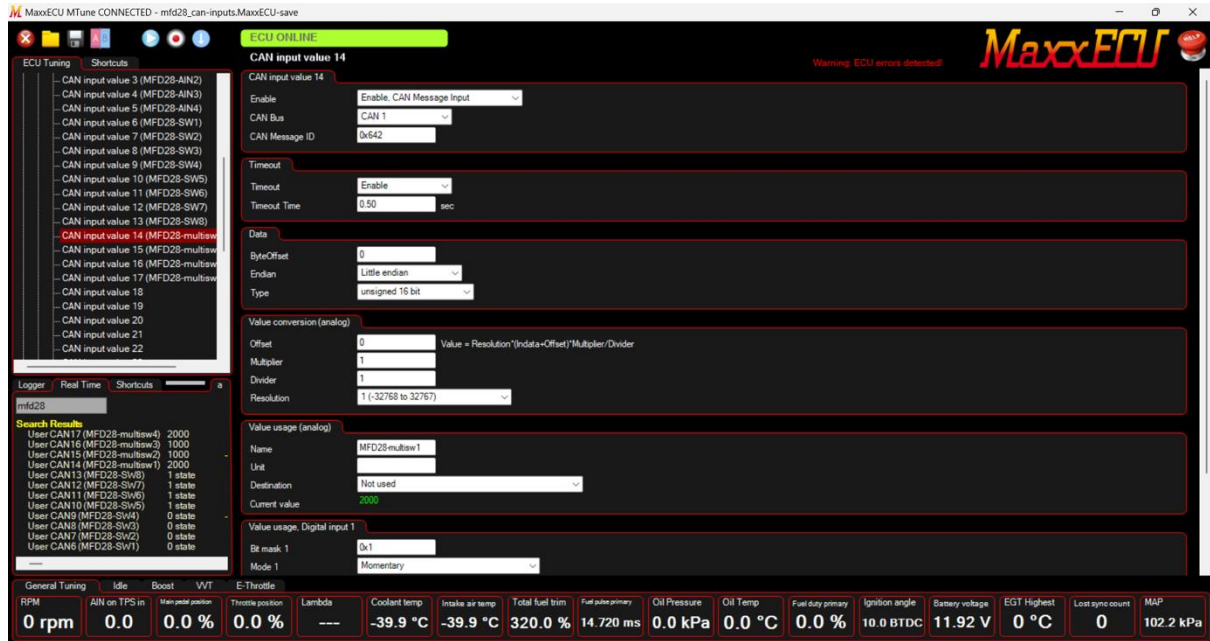

The 'byteoffset' changes again for the MultiSwitches: MultiSwitch1=0, MultiSwitch2=2, MultiSwitch3=4, MultiSwitch4=6

### 11.21 How can I switch an output

The MFD2832 has a switchable output. This can be triggered either manually by a virtual button (switch widget) or by a sensor threshold value.

#### 11.21.1 Virtual button

If you are using the current SD content, you can switch the output switch at the bottom left on page 3. If you still have old SD content, you can create the switch widget in the DSS as follows:

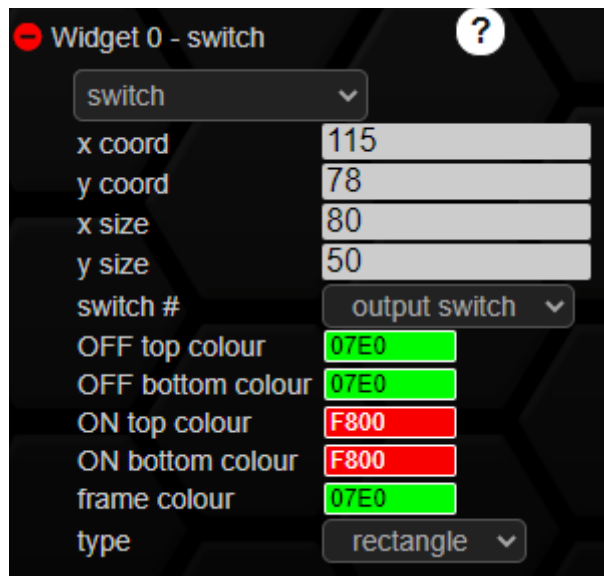

#### 11.21.2 Sensor threshold value

As an example, we would like to switch a relay that switches on an additional fan from a temperature of 80 degrees. The relay must be wired as follows:

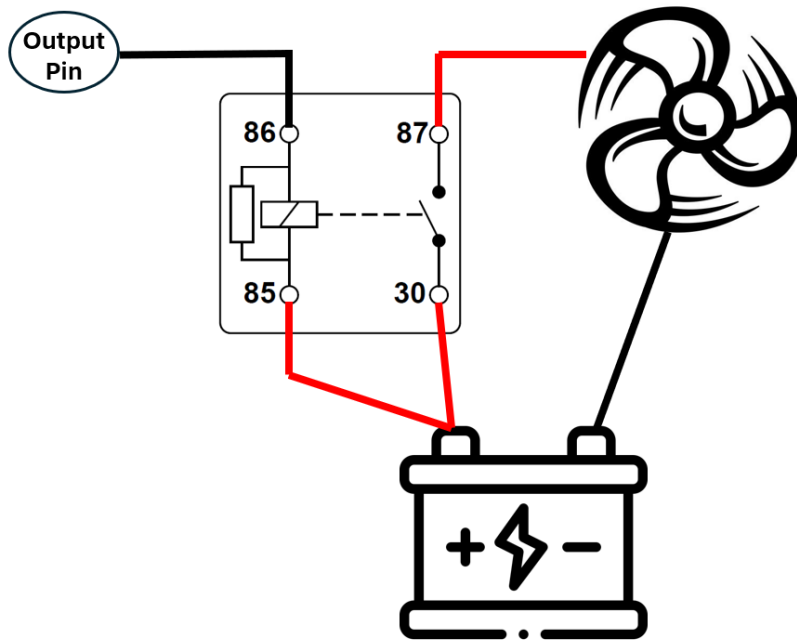

Under Other settings, we now assign the output pin and the corresponding status (ON/OFF) and export the setting to the display. We then create the sensor user table in the TRI Editor as described in chapter 9.5.8, export the setting to the display and then fill the user table under Other settings with the required threshold values:

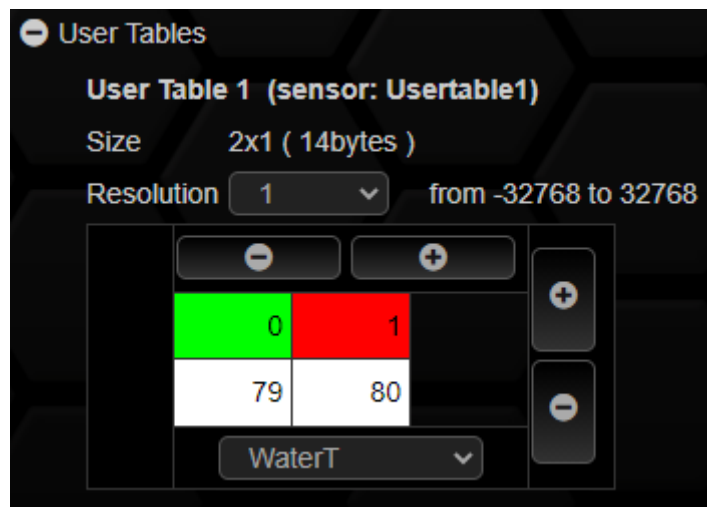

In the last step, we now add the usertable as an input variable for the output switch:

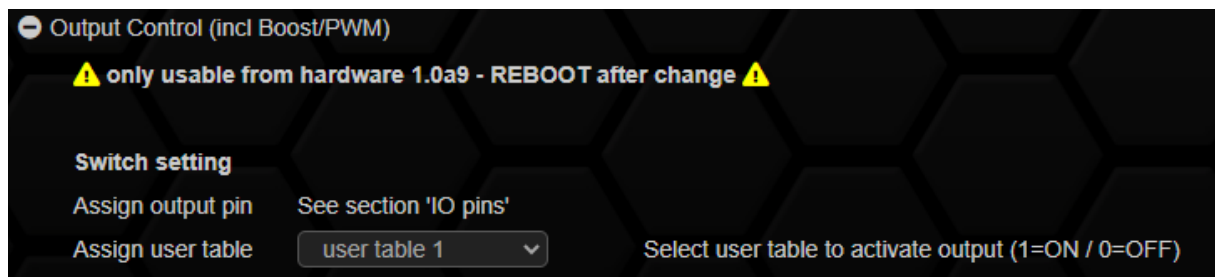

## 11.22 Can I dim my display

The display can be dimmed in various ways:

Either you use a Can Bus frame as an input variable for dimming, please refer to the corresponding sensor in the sensor init Dim Display (0=0% 255=100%).

Dimming via the brightness control on the display, see chapter 5.

Or you can assign a pin as an input pin for dimming (see chapter 9.5.6). You can choose between pins B1, B5 and B10. B5 and B10 dim on contact with ground (alternatively with 10k pull-up also against 5V) B1 dims on contact to 5-12V:

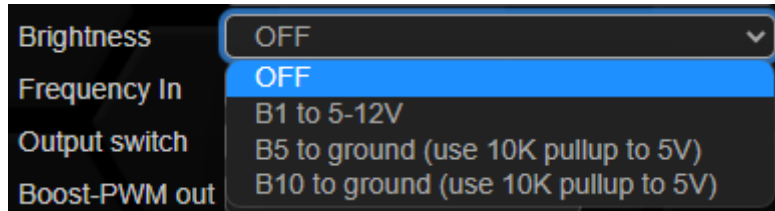

### 11.23 Can I change the page using an external button

Similar to dimming via an external switch via earth fault or against 5V with pull-up, the change of side can also be triggered externally. The following pins can be used for this purpose:

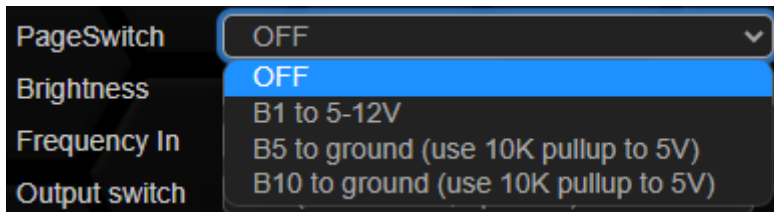

It is also possible to change the page via Can Bus Frames. To do this, a sensor for Page Switch must be assigned in the sensor init. Values from 1-10 can now be sent for this sensor and the display jumps to the page sent.

### 11.24 I can't add, move or delete widgets

If you can't add, move or delete widgets, it's because the Enhanced Mode button is set incorrectly. This button is located in the top right-hand corner of the DSS and must be switched on for you to use these functions.